

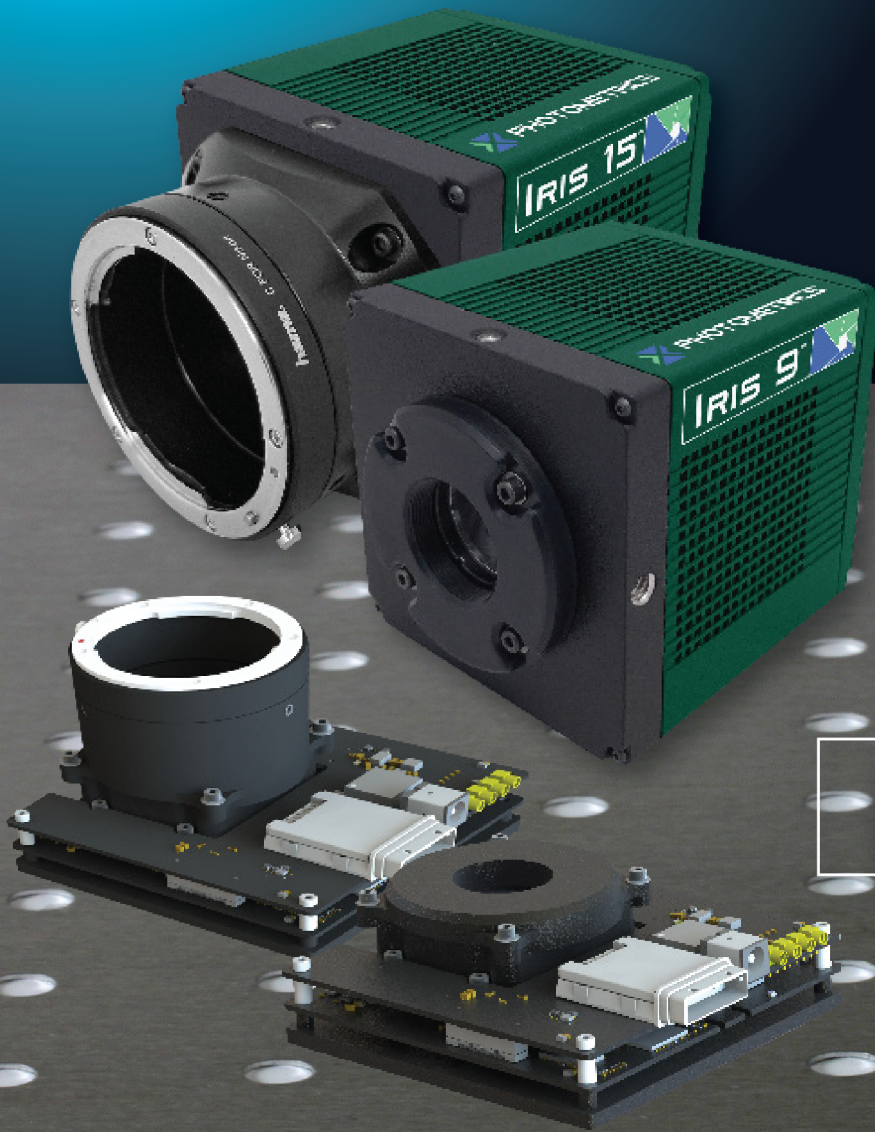

# PHOTOMETRICS®

CMOS, EMCCD and CCD Cameras for Life Sciences



## USER MANUAL



© Copyright 2018 Photometrics  
3440 East Britannia Drive  
Tucson, Arizona 85706  
Tel: +1 520.889.9933  
Fax: +1 520.295.0299

All rights reserved. No part of this publication may be reproduced by any means without the written permission of Photometrics.

Acrobat and Reader are registered trademarks of Adobe Systems Incorporated in the United States and/or other countries.

Photometrics and PVCAM are registered trademarks of Roper Technologies.

Iris is a trademark of Photometrics.

Intel Core is a trademark of Intel Corporation in the U.S. and/or other countries.

Windows is a registered trademark of Microsoft Corporation in the United States and/or other countries.

All other brand and product names are the trademarks of their respective owners and manufacturers.

The information in this publication is believed to be accurate as of the publication release date. However, Photometrics does not assume any responsibility for any consequences including any damages resulting from the use thereof. The information contained herein is subject to change without notice. Revision of this publication may be issued to incorporate such change.

## LIMITED WARRANTY

Photometrics (“Photometrics,” us,” “we,” “our”) makes the following limited warranties. These limited warranties extend to the original purchaser (“You”, “you”) only and no other purchaser or transferee. We have complete control over all warranties and may alter or terminate any or all warranties at any time we deem necessary.

### Basic Limited Two (2) Year Warranty

Photometrics warrants this product against substantial defects in materials and/or workmanship for a period of up to two (2) years after shipment. During this period, Photometrics will repair the product or, at its sole option, repair or replace any defective part without charge to you. You must deliver the entire product to the Photometrics factory or, at our option, to a factory-authorized service center. You are responsible for the shipping costs to return the product. International customers should contact their local Photometrics-authorized representative/distributor for repair information and assistance, or visit our technical support page at [www.photometrics.com](http://www.photometrics.com).

### Limited One (1) Year Warranty on Refurbished or Discontinued Products

Photometrics warrants, with the exception of the CMOS or CCD image sensor device (which carries NO WARRANTIES EXPRESS OR IMPLIED), this product against defects in materials or workmanship for a period of up to one (1) year after shipment. During this period, Photometrics will repair or replace, at its sole option, any defective parts, without charge to you. You must deliver the entire product to the Photometrics factory or, at our option, a factory-authorized service center. You are responsible for the shipping costs to return the product to Photometrics. International customers should contact their local Photometrics representative/distributor for repair information and assistance or visit our technical support page at [www.photometrics.com](http://www.photometrics.com)

### Normal Wear Item Disclaimer

Photometrics does not warrant certain items against defect due to normal wear and tear. These items include internal and external shutters, cables, and connectors. *These items carry no warranty, expressed or implied.*

### Software Limited Warranty

Photometrics warrants all of our manufactured software discs or memory devices to be free from substantial defects in materials and/or workmanship under normal use for a period of one (1) year from shipment. Photometrics does not warrant that the function of the software will meet your requirements or that operation will be uninterrupted or error free. You assume responsibility for selecting the software to achieve your intended results and for the use and results obtained from the software. In addition, during the one (1) year limited warranty, the original purchaser is entitled to receive free version upgrades. Version upgrades supplied free of charge will be in the form of a download from the Internet. Those customers who do not have access to the Internet may obtain the version upgrades on a CD ROM or USB memory device from our factory for an incidental shipping and handling charge.

## Owner's Manual and Troubleshooting

You should read the owner's manual thoroughly before operating this product. In the unlikely event that you should encounter difficulty operating this product, refer to the owner's manual. If the problem persists, please contact the Photometrics technical support staff or an authorized service representative.

## Your Responsibility

The above Limited Warranties are subject to the following terms and conditions:

You must retain your bill of sale (invoice) and present it upon request for service and repairs or provide other proof of purchase satisfactory to Photometrics.

You must notify the Photometrics factory service center within thirty (30) days after you have taken delivery of a product or part that you believe to be defective. With the exception of customers who claim a "technical issue" with the operation of the product or part, all invoices must be paid in full in accordance with the terms of sale. Failure to pay invoices when due may result in the interruption and/or cancellation of your two (2) year limited warranty and/or any other warranty, expressed or implied.

All warranty service must be made by the Photometrics factory or, at our option, an authorized service center.

Before products or parts can be returned for service you must contact the Photometrics factory and receive a return authorization number (RMA). Products or parts returned for service without a return authorization evidenced by an RMA will be sent back freight collect.

These warranties are effective only if purchased from the Photometrics factory or one of our authorized manufacturer's representatives or distributors.

Unless specified in the original purchase agreement, Photometrics is not responsible for installation, setup, or disassembly at the customer's location.

Warranties extend only to defects in materials or workmanship as limited above and do not extend to any product or part which has:

- been lost or discarded by you;
- been damaged as a result of misuse, improper installation, faulty or inadequate maintenance, or failure to follow instructions furnished by us;
- had serial numbers removed, altered, defaced, or rendered illegible;
- been subjected to improper or unauthorized repair; or
- been damaged due to fire, flood, radiation, or other "acts of God" or other contingencies beyond the control of Photometrics.

After the warranty period has expired, you may contact the Photometrics factory or a Photometrics-authorized representative for repair information and/or extended warranty plans.

Physically damaged units or units that have been modified are not acceptable for repair in or out of warranty and will be returned as received.

All warranties implied by state law or non-U.S. laws, including the implied warranties of merchantability and fitness for a particular purpose, are expressly limited to the duration of the limited warranties set forth above. With the exception of any warranties implied by state law or non-U.S. laws, as hereby limited, the forgoing warranty is exclusive and in lieu of all other warranties, guarantees, agreements, and similar obligations of manufacturer or seller with respect to the repair or replacement of any parts. In no event shall Photometrics' liability exceed the cost of the repair or replacement of the defective product or part.

This limited warranty gives you specific legal rights and you may also have other rights that may vary from state to state and from country to country. Some states and countries do not allow limitations on how long an implied warranty lasts, when an action may be brought, or the exclusion or limitation of incidental or consequential damages, so the above provisions may not apply to you.

When contacting us for technical support or service assistance, please refer to the Photometrics factory of purchase, contact your authorized Photometrics representative or reseller, or visit our technical support page at [www.photometrics.com](http://www.photometrics.com).

## **U. S. Government Restricted Rights**

The software and documentation are provided with Restricted Rights. Use, duplication, or disclosure by the Government is subject to restrictions as set forth in subparagraph (c)(1)(ii) of the Rights in Technical Data and Computer Software clause at DFARS 252.227-7013 or subparagraphs (c)(1) and (2) of the Commercial Computer Software-Restricted Rights at 48 CFR 52.227-19, as applicable. Contractor/manufacturer is Photometrics, 3440 East Britannia Drive, Tucson, AZ 85706.

This license is effective until terminated. It will terminate upon the conditions set forth above or if you fail to comply with any term hereof. Upon termination, you agree that the software and accompanying materials, and all copies thereof, will be destroyed. This agreement is governed by the laws of the State of Arizona. You acknowledge that you have read this agreement, you understand it, you agree to be bound by its terms, and that this is the complete and exclusive statement of the agreement between you and Photometrics regarding the software.



# CERTIFICATE OF CONFORMITY

*This certificate is to recognize*

<b>Holder:</b>	PHOTOMETRICS
<b>Address:</b>	3440 E. Britannia Drive, Suite 100, Tucson, AZ 85706
<b>Product:</b>	Iris 9 Camera
<b>Identification:</b>	Iris Camera
<b>Standards:</b>	FCC Part 15, Subpart B ICES-003 Issue 6 EN 61326-1:2013 CISPR 11:2009/A1:2010 EN 61000-3-2:2014 EN 61000-3-3:2013

**Summary:** QAI Laboratories confirms that the product tested as outlined in report E10585-1801 Rev 0.0 complies with the standards listed above. This certificate does not imply assessment of the production of the product and does not permit the use of a QAI mark of conformity. Photometrics declares that the product tested represents the equivalent or worst case equipment under test and that any testing performed by QAI Laboratories applies equally as well to models:

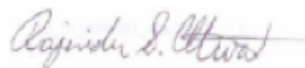

Rajinder S. Atwal, Engineering Manager-  
EMC Department



Parminder Singh, Director-  
EMC Department

Certificate # E10585-1703\_Photometrics\_Rev1.0

Issued Date: May 09, 2018  
Expiration Date: N/A

# Table of Contents

<b>Overview .....</b>	<b>1</b>
About This Manual .....	1
Precautions .....	1
Environmental Requirements .....	2
Storage Requirements .....	2
Microscopes, Lenses, and Tripods .....	2
Repairs .....	2
Cleaning .....	2
 <b>System Installation .....</b>	 <b>3</b>
Introduction .....	3
Getting to Know Iris .....	4
Software Compatibility Requirements .....	4
Host Computer Requirements .....	5
Software Installation .....	5
Installing the PCI Express Interface Card .....	6
Connecting Iris to the PCIe Bus.....	8
Connecting Iris with USB3.0 .....	9
 <b>Theory of Operation .....</b>	 <b>10</b>
Introduction .....	10
CMOS Image Sensor Structure .....	10
Gain Combining and Bit-Depth .....	11
Digital Binning .....	13
Sensor Clearing.....	13
Bias Offset.....	14
Pixel Noise Filters.....	14
 <b>Operating Features .....</b>	 <b>17</b>
Introduction .....	17
Operating Frequencies.....	17
Gain States .....	17
Bias Offset Setting .....	17
Clearing Mode Selection .....	18
Device Synchronization (Triggering).....	19
Trigger Modes .....	20
Expose Out Behaviors.....	20
SMART Streaming .....	24
Cooling.....	24
Advanced Features .....	24

<b>Troubleshooting .....</b>	<b>25</b>
System Does Not Boot Normally .....	25
New Hardware Found Dialog Box Does Not Appear .....	25
Images Not Displayed .....	26
Camera Running Too Warm .....	26
PVCAM Error Message Appears .....	26
Lengthy Pauses During Imaging .....	26
<b>Basic Specifications .....</b>	<b>27</b>
Iris Scientific CMOS:	
Front, Side And Rear Views .....	27
Camera Weight .....	27



## Chapter 1.

# Overview

---

### About This Manual

This Iris Scientific CMOS Camera User Manual is divided into five chapters. Photometrics recommends you read this entire manual before operating the camera to ensure proper use. The chapter contents are briefly described below.

**Note: The information in these chapters applies only to the Iris Scientific CMOS and is currently not applicable to any other Photometrics camera.**

- **System Installation** — Instructions for connecting the Iris Scientific CMOS camera to a computer via the PCI Express interface card or the USB3.0 bus.
- **Theory of Operation** — A basic overview of Scientific CMOS camera technology as used in the Iris Scientific CMOS camera.
- **Operating Features** — Iris features and how to optimize them for speed and sensitivity, and how to use the different trigger modes.
- **Troubleshooting** — Answers to common camera system questions.
- **Basic Specifications** — Specifications for Iris system components.

### Precautions

The CMOS sensor and other system electronics are extremely sensitive to electrostatic discharge (ESD). To avoid permanently damaging the system, please observe the following precautions:

- If using high-voltage equipment (such as an arc lamp) with the camera system, turn the camera power on last and when powering down, power the camera off first.
- Never connect or disconnect any cable while the system is powered on.
- The camera's power should be switched off before disconnecting any camera system cables. However it is not necessary to power off the computer to detach the cables.
- Use caution when triggering high-current switching devices (such as an arc lamp) near the system. The image sensor can be permanently damaged by transient voltage spikes. If electrically noisy devices are present, an isolated, conditioned power line or dedicated isolation transformer is highly recommended.
- Always leave one inch of space around the camera for airflow.

- Never open the camera. There are no user-serviceable parts inside the Iris Scientific CMOS camera. Opening the camera voids the warranty.
- Use only the PCI Express interface card, cables and power supply designated for this camera system. Using non-Iris cables, PCI Express interface cards or power supplies may result in permanent damage to the system.

## Environmental Requirements

The Iris Scientific CMOS camera system should be operated in a clean, dry environment. The camera system's ambient operating temperature is 0°C to 30°C with 80% relative humidity, non-condensing.

## Storage Requirements

Store the Iris Scientific CMOS camera system in its original packaging. To protect the system from excessive heat, cold and moisture, store at an ambient temperature between 0°C and 40°C with a relative humidity of 0% to 90%, noncondensing.

## Microscopes, Lenses, and Tripods

The camera has two standard mounting options and can be coupled to any optical system or microscope that accepts a standard C-mount adapter for the Iris 9, or a standard F-mount adapter for the Iris 15. The camera also allows you to install any lens that is compatible with either of these threaded video mounts if its optics do not extend behind the flange of the lens. Iris can be mounted to optical tables, tripods or custom stands using the four ¼-20 threaded attachment points located near the front of the camera housing on all sides.

## Repairs

Please save the original packing materials so you can safely ship the camera to another location or return it for repairs if necessary. The Iris Scientific CMOS camera system contains no user-serviceable parts. Repairs must be done by Photometrics. Should the camera system require repairs, please contact Photometrics Customer Service.

**Note: Do not open the camera. Opening the Iris Scientific CMOS voids the warranty.**

## Cleaning

Clean exterior surfaces of the camera with a dry, lint-free cloth. To remove stains, contact Photometrics Customer Service. To clean the camera's imaging window, use only a filtered compressed-air source. Hand-held cans are not recommended as they may spray propellant onto the window. Do not touch the window.

## Chapter 2.

# System Installation

---

Carefully review the Precautions section in the previous chapter before performing any of the procedures outlined in this chapter. Again, use only a Iris Scientific CMOS PCI Express data cable and Iris PCI Express interface card with the camera. Using a different cable or interface card may result in permanent damage to the system.

### Introduction

The Iris Scientific CMOS camera system includes the following hardware components:

- Iris Scientific CMOS Camera
- PCI Express (PCIe) interface card (For PCIe cameras only)
- PCI Express data cable (For PCIe cameras only)
- USB 3.0 SuperSpeed A to B data cable (For USB cameras only)
- A 12V/ 5A power supply with international power cord set
- Two single-line MMCX trigger cables
- USB memory device containing PVCAM library and drivers
- Quick Installation Guide

Iris system components are linked by the PCI Express or USB3.0 data cable and controlled by the host computer system. All of these hardware components should be included with the shipment. Keep all the original packing materials so you can safely ship the camera to another location or return it for service.

If you have any difficulty with any step of the instructions, contact Photometrics Customer Service.

## **Getting to Know Iris**

Highlights of the Iris Scientific CMOS camera:

- USB3.0: Data Connection
- DATA: High Speed PCI-Express Connection
- Initializing: LED blinking indicates the camera is initializing
- Trigger: Single-line MMCX trigger cables
- DC IN: Connection to external 12V 5A DC power supply

The Iris camera package includes the PVCAM camera control software library and drivers needed to use the camera with a variety of third party imaging software. To obtain the latest version of the library and drivers visit the Photometrics website. The Photometrics website also contains listings of third party software applications that support the Iris.

## **Software Compatibility Requirements**

Unless there is a preferred version specified by a third party software provider, the latest version of PVCAM is recommended for use with Iris.

## Host Computer Requirements

The host computer (PC) for Iris must meet the following minimum requirements:

- Windows 8/10 64-bit operating system
- 2.0 GHz or faster Intel processor: either Xeon or Core i7
- 8+ GB RAM
- 250+ GB serial ATA (SATA) HDD and/or >512 GB solid state drive (SSD) for high-speed imaging and storage
- 512+ MB slot-based ATI/NVIDIA video graphics card (i.e., not an “onboard/integrated graphics” adapter)
- USB port for use with the USB memory device or Internet access to obtain the PVCAM library and interface drivers
- USB3.0 port for use with the Iris USB3.0 interface
- An open PCI-Express 4x (4 lane) interface slot or higher for use with the Iris PCIe interface card

## Software Installation

An appropriate *Installation Guide* is included as an insert with the camera. This guide provides step-by-step instructions for installing the camera interface software for Windows-based computers. Additional instructions are included for installing a PCI Express interface card in the computer.

The Photometrics USB memory device contains the following files:

- Manuals Directory — contains user manuals in PDF format.
- Customer Case Studies — application examples
- Imaging Software – a copy of Open Imaging’s Microscopy Application: Micromanager
- Technical Notes – detailed background on advanced features

For a 64-bit Windows OS, install PVCam64\_Setup\_X\_X\_X\_X.exe (latest version is on drive)

For a 32-bit Windows OS, install PVCam32\_Setup\_X\_X\_X\_X.exe (latest version is on drive)

Follow the *Installation Guide* insert for the version of Windows being used. Reboot the computer when the installation is complete.

## Installing the PCI Express Interface Card

Because of the data rate resulting from 32fps 5056 x 2960 imaging with a 16-bit output, the data rate of the Iris camera is significantly higher than previous generations of scientific cameras. At 958 MB/s, Iris requires a more powerful computer interface than previous generations of cameras to obtain the maximum frame rate. For this reason, Iris is supplied with a high speed PCI Express bridge card that is capable of sustaining the bandwidth requirements of the camera.

**TIP: PCI Express is a high speed peripheral data bus used by the computer to communicate with video cards, high speed Solid State Drives, and image frame grabbers. The PCI Express interface card is simply an adapter between the computer's internal PCIe bus and the camera.**

**While this has benefits in cost, reliability, simplicity, and performance, it is important that the camera is powered on for 10 seconds before starting the PC. This will ensure that as the computer goes through the boot process, it discovers the camera on the PCIe bus.**

Install the High Speed PCI Express Interface

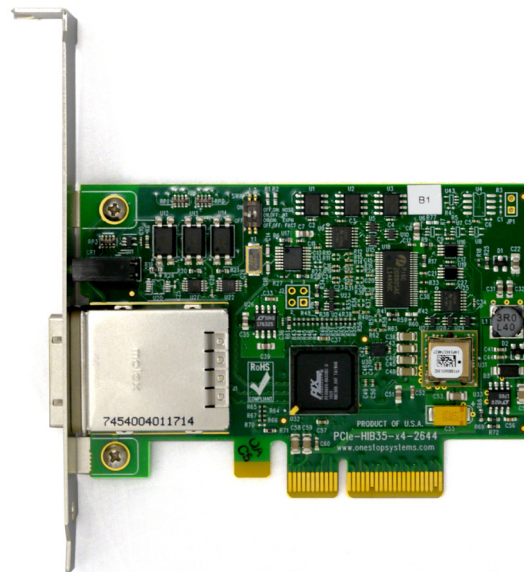

**Note: The model of PCIe card shipped with the camera may differ from the one shown in the photo.**

**Warning: Do not use the PCIe interface supplied with the QImaging optiMOS Scientific CMOS camera with the Photometrics Iris Scientific CMOS camera. While they have a common cable and connector, they are not compatible.**

Before attempting to operate the camera, first install this interface card into the PC with the following steps:

1. Shut down the PC
2. Unplug the PC from power mains and ensure the camera is turned off
3. Open the side of the computer to access the PCI and PCIe slots



4. Locate an available 4 channel or higher PCIe slot (marked x4). Refer to the PC's documentation to locate a suitable slot.

**Tip: The PC may have motherboard slot information on the side cover**

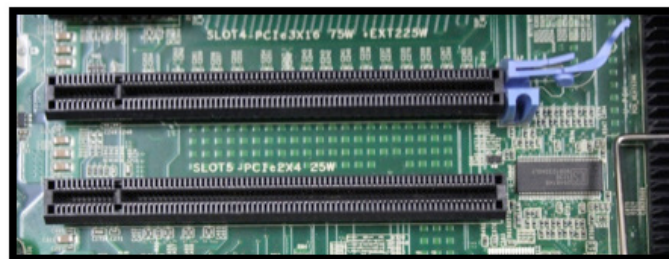

5. Holding the Iris PCIe card and (being careful not to touch the board components or PCIe bridge pins) insert it with the proper orientation into the open slot. The card should slide into place with minimal resistance and snap when fully inserted.

## Connecting Iris to the PCIe Bus

The Iris Scientific CMOS camera data cable is a quick insertion, quick release cable that works with the interface card and camera. Either end of the cable can be plugged into either device, and in any order.



The connector can only be inserted with the correct orientation, do not force the connector. If the connector does not insert, simply turn the connector over and retry.

**Hint: With the camera oriented so the labels on the camera are upright, the green “quick release” pull tab on the cable will be facing down.**

Connect the PCIe interface cable to both the camera and PC.

Connect the power supply to the Power connector on the rear of the camera.

Plug the power cord into the power supply and then into a suitable wall outlet. There is no power switch on the Iris, plugging the power supply into a live outlet will power the camera. LED will be blinking after power on.

Start up steps for Iris PCIe camera:

1. Power on camera
2. LED blinks while camera calibration is loading in the background
3. Power on host PC computer
4. LED off — background loading completed
5. Camera is initialized and ready to communicate

**Tip: The power supply and connector used by the Iris Scientific CMOS camera is a common type. However, Photometrics carefully selects power supplies for optimum noise performance, EMI compliance and stability. Do not swap power supplies with other lab equipment even though they may meet the connector, voltage and ampere requirements of the Iris.**



## Connecting Iris with USB3.0

Iris's USB3.0 interface is ubiquitous and easy to use. To use the interface, the PC must have an open USB3.0 port. Iris is not USB2.0 compatible. USB3.0 ports are usually indicated by the SuperSpeed+ logo and are typically blue in color.

**Tip: USB devices sharing the same bus as Iris contend for available bandwidth, potentially causing the camera to drop frame rate. For this reason, Photometrics recommends isolating the camera to its own USB3.0 root hub as shown in the Windows Device Manager.**

**A method for creating an independent root hub in computers with many USB devices is to install a PCI Express based USB3.0 interface card for use with the camera. In this case Photometrics recommends using the PCIe interface described above, as it also provides improvements in maximum frame rate.**

**It is not recommended to connect to Iris external USB3.0 hubs.**



Note that the ends of the USB3.0 cable are different between the camera and PC, and require a specific orientation. The camera has a "Micro-B" connector and the computer will have a "Type A" connector. Do not force insertion when connecting the cable – if significant resistance is encountered stop, reexamine the connection, and if correct, retry.

With the USB 3.0 cable connected on both the camera and PC you are now ready.

Connect the power supply to the Power connector on the rear of the camera. There is no power switch on the Iris, plugging the power supply into a live outlet will power the camera.

Plug the power cord into the power supply and then into a suitable wall outlet. LED will be blinking after power on.

Start up steps for Iris PCIe camera:

1. Power on host PC computer
2. LED on backplate blinks while camera calibration is loading in the background
3. Power on host PC computer
4. LED on backplate off — background loading completed
5. Camera is initialized and ready to communicate

## Chapter 3.

# Theory of Operation

---

### Introduction

Backside illuminated scientific CMOS (BSI Scientific CMOS) sensors are a recent development in image sensor technology. BSI CMOS sensors are able to provide the highest levels of sensitivity with a near perfect 95% quantum efficiency (QE). This QE coupled with large pixel CMOS sensors which have high frame rates, high pixel counts, and low electronic noise provide the most complete low-light scientific imaging solution.

### CMOS Image Sensor Structure

A major difference between traditional CCD sensors and CMOS sensors is the location where charge-to-voltage conversion of accumulated photoelectrons takes place. CCD sensors transfer the pixels accumulated signal in charge packets in “bucket brigade” fashion across the sensor to a common output node where charge is converted to a voltage. The voltage is then sampled using off-chip Analog-to-Digital Converters (ADC) and transferred to the PC as digital grey values.

While providing excellent quantitative photometry and very high image quality, the large number of transfers and sequential digitization of pixels results in low frame rates. This speed penalty increases with the number of pixels to be digitized.

CMOS sensors leverage many of the same analog signal concepts used in CCDs, but places the output node circuitry inside each pixel. This eliminates the charge transfer process. To read the signal from a given row, the accumulated charge is converted to a voltage inside the pixel, then each pixel in the row is connected to the appropriate column voltage bus, where the on-chip ADCs convert the voltages to an 11-bit or 12-bit grey value. (Thus far, the on-chip ADCs available on CMOS sensors have limited dynamic range.)

The parallel digitization of all pixels in a row provides CMOS devices with a tremendous speed advantage. Imagine a CCD with 2048x2048 pixels – and each pixel's voltage is measured in 1 usec. To read a single row, 2048 voltage measurements are performed in serial fashion taking slightly longer than 2 ms, and when repeated for 2048 rows, the entire image takes over four seconds to be digitized.

On a CMOS device – the entire 2048 voltage conversions needed to digitize a row happen in parallel. The sensor in the Iris Scientific CMOS camera takes parallelism even further by dividing the sensor into two halves, so that two rows of 2048 pixels can be measured at the same time. If the time to digitize a pixel remains at 1 us – the time to read the entire frame is now ~ 1 ms.

In practice, the time saving is split between faster frame rates and slowing the rate of pixel measurement to reduce electronic noise. For example, if the time to measure a pixel was increased to 10 usec to lower noise, the image sensor can still be read in 10 ms (for a maximum 100fps).

Of course, there are many challenges to obtaining the same analog performance from each of the Iris's nine (or fifteen) million pixels, whereas a CCD has a single, common output node resulting in a uniform response. The most common problems are pixel-to-pixel non uniformity in gain and offset, random telegraph noise (RTN), and defective pixels with abnormal noise or dark current characteristics (hot pixels).

Often solutions to these challenges are found in the digital domain, where Iris's advanced real time signal processing corrects each pixel for gain and offset variation using calibration at the factory. To address RTN and other pixel defects, real-time digital filters are used. These corrections are described further in this manual.

## Gain Combining and Bit-Depth

As discussed in the previous section, the column ADCs present in Scientific CMOS devices have limited dynamic range. This is addressed by making two measurements of the accumulated charge in each pixel – the first with very high sensitivity but limited to a maximum signal of approximately 1000 electrons, and the second with reduced sensitivity but capable of measuring signals up to the **pixel's ~14,000 electron full well capacity**.

Combining the two measurements into a single 16-bit value is the function of the digital "gain combiner". This mathematical operation is performed on the camera's FPGA. **The result is a single 1x gain of approximately 0.22e/ADU.**

In practice, Iris's advanced FPGA based signal processing does an excellent job of gain combining as evidenced by the quality of gamma transfer functions (linearity) and photon transfer functions (signal versus noise). With careful observation and uniform illumination of the sensor, the zone where two measurements overlap can be seen as a slight static vertical pattern in the image. This is inherent on all current Scientific CMOS generation Scientific CMOS cameras. While impacting image quality, these cannot be addressed without negatively impacting image photometry and wait for further improvements to the on-sensor ADC conversion.

## Rolling and Global Shutter Readout

Rolling Shutter and Global Shutter are the two primary operating modes of CMOS image sensors. In Global Shutter readout, a global charge clearing mechanism begins the exposure period for all pixels. Each pixel accumulates signal charge until the exposure period ends. At this point, the accumulated charge is transferred and converted to a voltage in the pixels output node, ending the exposure.

The strength of the Global Shutter approach is that all pixels are exposed at the same instant in time – an important attribute when imaging fast moving objects. The downside of this approach is the sensor has two phases, an active image accumulation phase and a subsequent readout phase. As the phases are not overlapped in time, the maximum achievable frame rate is lower.

In Rolling shutter readout, exposure and readout are overlapped. This is accomplished by reading one row, while exposing all of the other rows (The row being digitized “rolls” through the sensor).

For Iris, the time to digitize a single row is 10.26µsec for PCIe and 20.42µsec for USB 3.0 and consequently the delay between the start of exposure between two adjacent rows is approximately 10.26µs (or 20.42µs). Digitizing 2960 rows of pixels, the time delay from the top to the middle of the sensor is approximately 30.4 ms. Since readout and exposure are overlapped, the sensor achieves the maximum frame rate of 32fps with PCIe interface (Iris 9 and Iris 15) and 16fps for Iris 9 USB/ 10.5fps for Iris 15 USB).

The graphic below depicts the time delay between each row of pixels in a rolling shutter readout mode with a CMOS camera.

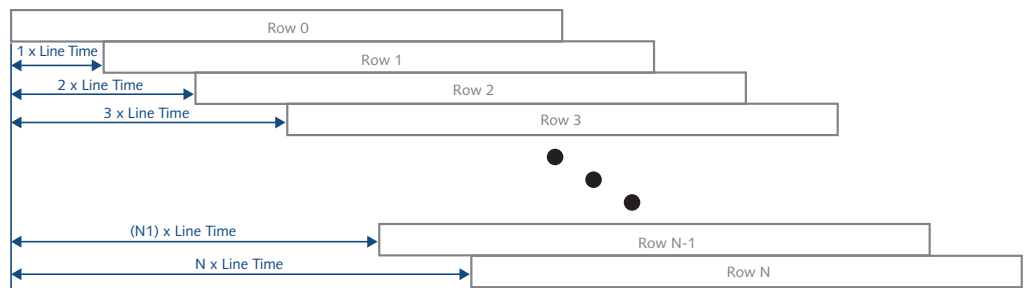

*Rolling Shutter Exposure Row by Row Exposure Start/End Offset*

The downside of Rolling Shutter readout is that changes in the scene on similar time scales is distorted, as each row samples the image at different times. This is the well-known “rubber band” effect – but can appear in fluorescence microscopy as shaded illumination when rapidly changing wavelengths.

To maintain the benefit of Rolling Shutter readout and eliminate rolling shutter artifacts, external illumination can be gated on when all rows are being simultaneously exposed, and off during the readout phase. This external triggering mode used in combination with high speed light sources (lasers, LEDs) achieves a pseudo global shutter effect. This triggering mode is described in the device synchronization section of this manual.

## Digital Binning

Highlights of the Iris Scientific CMOS camera are shown below: CCD image sensors are capable of charge binning (combining adjacent pixels into one super pixel). This is accomplished as part of the charge transfer process and has the advantage of increasing signal to noise in read-noise limited situations, at the expense of spatial resolution.

The lack of a charge transfer process in CMOS devices means true charge binning is not available in currently available Scientific CMOS sensors. Even so, co-adding pixels is a convenient means to reduce image data, or increase signal by 4x and improve SNR by 2x as the noise from each pixel adds in quadrature.

Iris includes 2x2 on-camera simulated binning, done on the FPGA. This mathematically combines signal from adjacent pixels and adjusts the sum so that the bias offset is only added one time.

## Sensor Clearing

In order to capture the highest signal to noise ratio possible, it is important that scientific cameras minimize any signal that's not derived from the sample. One contribution to this background signal is the buildup of charge prior to an exposure, which includes any light still reaching the sensor and thermally generated sensor dark current. To eliminate this pre-acquisition charge accumulation, most CCD and CMOS cameras clear the sensor one or more times prior to exposing the sensor to light. This can be done using a “fast” readout that is subsequently discarded, or using additional circuitry that performs a global reset of all pixel photosites.

Unlike CCDs, there is limited benefit to performing multiple pre-exposure clearing cycles with CMOS, because each pixel is reset as part of the normal readout process, and the charge transfer registers that can hold residual signals are not present.

## Bias Offset

Scientific cameras produce a fixed artificial signal offset known as bias offset. This offset is present even when no light is falling on the sensor and the exposure time is set to zero. This preserves quantitation even down to signals of a few electrons per pixel. Typically, the user subtracts this offset before performing quantitative analysis post-acquisition.

The recommended protocol is to capture a new series of bias frames at the start of each experimental run. The series of frames can be averaged to remove noise, then used to remove the bias offset during subsequent image analysis. This can also be used to monitor for light leaks and other systematic effects that can impact experimental results.

## Pixel Noise Filters

**Note: The Iris Scientific CMOS camera ships with an optimized default setting for Real Time Pixel Noise Filtering. Normally these values do not need to be adjusted. Additionally, the features described in this section may not be controllable in the software application. This is an advanced usage section.**

In the CMOS sensor section, it was noted that a drawback to current CMOS sensors is variability in pixel to pixel response. This variability falls into two categories, static variation in gain and offset and dynamic fluctuations that require real-time Pixel Noise Filters, also known as “Despeckling”.

The static variation in gain and offset is measured and a correction factor is determined for every pixel. This fixed pattern noise is measured during manufacture and the corrections are stored in the camera. These corrections are then applied in real-time to each image.

The dynamic fluctuations must be detected and corrected in real-time. Iris has several noise filters for this purpose. Defect detection is based on use of a conditional median filter. The 3x3 neighborhood surrounding a pixel is examined. If the pixel's value exceeds or falls below the median by a given amount, its value is replaced by the median.

Four filters are available:

Real-time Filters for Random Telegraph Noise:

1. *Despeckle* Dark Low
2. *Despeckle* Bright Low

Real-time Filters for Bright (Hot) or Dark Pixels:

3. *Despeckle* Dark High
4. *Despeckle* Bright High

“Dark” filters work on the low side of the local median, while “Bright” filters work on the high side of the local median. The filter is only applied if the pixel’s value exceeds (or is below) a threshold expressed as a percent of the local median x 100.

For example, a *Despeckle Dark Low* threshold of “97” indicates that a pixel that is 3% below the local median will be replaced with the local median. A *Despeckle Bright High* threshold of “300” indicates that a pixel that is 200% brighter than the local median will be replaced.

The intensity range where each filter operates can be set by a value known as “Minimum ADU AFFECTED”. Take the “Dark” filters for example – pixel values that fall below the Minimum ADU Affected will be operated on using *Despeckle Dark Low*, and pixel values that lie above the *Minimum ADU Affected* will be operated on using *Despeckle Dark High* settings.

Given the new terminology – a simplified way to visualize the region in which each filter operates is shown below:

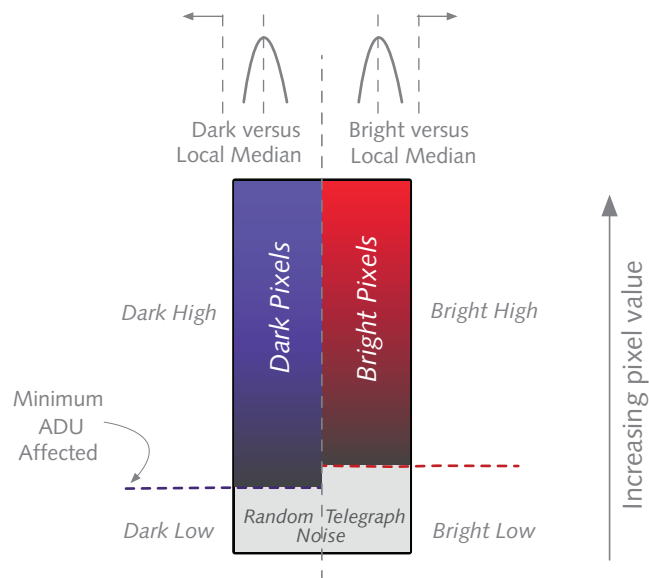

The general principle for setting the pixel noise filters is to use as little filtering as possible. Often the best way to determine this is viewing a real-time histogram with log scaling of the frequency. For setting “Dark Low” and “Bright Low”, block any light from reaching the sensor and examine the bias histogram. This allows viewing the histogram’s tail, where the effect of the filters can be seen. Adjust the filters to trim the non-Gaussian tails from the distribution.

For “Dark High” and “Bright High”, observe the image with flat, even illumination in the expected range to be observed. Adjust “Bright High” to eliminate most of the bright speckles, and adjust “Dark High” to eliminate any dark speckles that might appear.

Although they can be set independently, it is recommended to keep the Minimum ADU Affected the same for the dark filters and bright filters. This this value should be set approximately 1.5X the bias level to ensure the Low filters are operating on RTN noise.

## Signal Processing

The Iris has additional special capabilities that go well beyond the sensor. It is designed with high-speed DDR3 memory and high speed FPGA's (Field Programmable Gate Arrays) in order to provide new opportunities for extracting the best information from acquired images.

Photometrics has leveraged the revolution in computational imaging with many new capabilities. The Iris making computational imaging technology easy to deploy and accessible by embedding computational power inside the camera.



## Chapter 4.

# Operating Features

---

### Introduction

This section explains Iris's different modes of operation and the best modes to optimize imaging performance.

### Operating Frequencies

Iris has a single pixel rate or speed: **480 Mpixels per second**. System performance is optimized for this data rate, delivering the highest frame rates while maintaining the lowest noise, which delivers the best imaging quality. The need to change readout rates is eliminated.

### Gain States

Iris has a single, 16-bit combined gain value. The need for providing multiple gain choices is largely eliminated through the use of the gain combiner.

### Bias Offset Setting

The factory default bias level is approximately ~300 DN. If supported by the software application being used, the bias level can be changed. It is recommended that this value not be changed as the preset values for the defective pixel noise filters are set with this value.

## Clearing Mode Selection

In normal video-rate imaging, Iris’s clearing mode should be set to “Clear Pre-Sequence”. In “Clear Pre-Sequence”, one sensor clear occurs prior to acquiring an image sequence, but no extra clearing is done between frames. This eliminates unnecessary sensor clearing and maximizes frame rates.

If a CMOS sensor has an electronic global clearing function, “Clear Pre Sequence” also ensures there is no sensor clearing while readout is taking place, otherwise a portion of the image would be removed before it could be digitized.

The following waveforms show how the overlap behavior of “Clear Pre-Sequence” functions for the Iris camera.

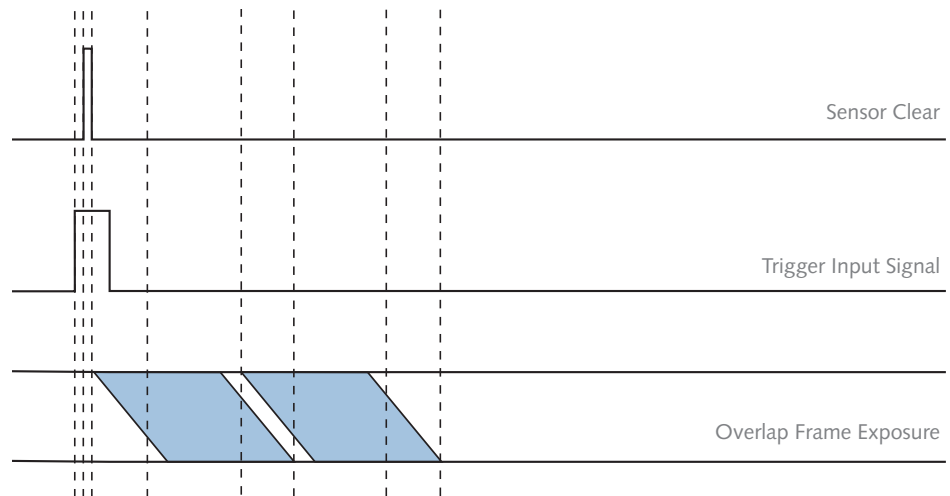

**Tip: In some software applications, multiple clearing modes may be listed as they are required for other cameras, but when using Iris, be sure to only use “Clear Pre-Sequence”.**

For time-lapse acquisitions with a significant delay between frames, clearing before each exposure may be necessary to clear accumulated dark current. If the time lapse is acquired under computer timing control, individual snaps taken with “Clear Pre-Sequence” turned on will be cleared with each new acquisition.

If the time-lapse is acquired using timing generated by the camera or an external timing generator, “Clear Pre-Sequence” will clear the sensor only for the first frame. In this case, “Clear Pre-Exposure” should be used as there is no concern over maximizing frame rate when each frame is separated by several seconds or more.

## Regions Of Interest

Regions of Interest (ROIs) are image sub regions selected by the user to be captured and delivered to the host PC in place of the full image. This can substantially increase frame rates and lower the amount of data that needs to be processed.

Frame rates increase with decreasing numbers of rows contained in the ROI. By reducing the number of rows, frame rates above 1000fps are achievable with small ROIs. As a result, the sensor architecture, if any pixel in a row is part of the ROI, the entire row is digitized. Reducing the number of columns in the ROI does not improve the frame rate of the camera, but it does reduce the amount of data acquired, saving computer resources and processing time.

**Note: Very small ROI's of less than 2000 pixels can result in data transfer problems during high-speed DMA data transfers to host memory. If a small ROI does not return an image, try changing the ROI pixel area to make it larger than 2000 pixels, or chose a different starting pixel for the ROI.**

## Device Synchronization (Triggering)

Iris offers several methods of integrating with external hardware devices. Each camera has four MMCX connectors on the back of the camera for trigger input/output operations. The signals provided to the user are:

Trigger In (TRIG IN)	Inputs initiate an exposure or sequence
Trigger Ready Out (TRIG RDY)	Status indicating if the camera can accept another trigger
Read Out (RD OUT)	Status indicating the camera is currently digitizing
Expose Out (EXP OUT)	Output for controlling illumination source 1

Single-line microminiature co-ax (MMCX) cables are included with the camera to access these functions. Each signal requires a cable that can be read with an oscilloscope or signal analyzer.

## Trigger Modes

### Timed Mode (Internal)

Timed mode is the default triggering mode for Iris. This means, the software/application initiates the start of a sequence of acquisitions. Once initiated, each frame captured in the sequence is controlled by the internal timing generators of the camera. Camera settings, expose out behavior and sequence size are set in the software application prior to acquiring the sequence. Timed mode is used when synchronization with other devices is either not required or is controlled independently through the software.

### Trigger-First Mode

Similar to Timed Mode but requires a hardware trigger from the I/O connector. Hardware triggers enable a higher precision of acquisition timing than software triggers. Rising edge of an external trigger initiates the start of a sequence of acquisitions. Once initiated, each frame capture in the sequence is controlled by the internal timing generators of the camera. Camera settings, expose out behavior and sequence size is set in the software application prior to acquiring the sequence.

### Edge Mode (Strobed Mode)

Like Trigger-First Mode, Edge Mode requires a hardware trigger but this time for every frame. The rising edge of the external trigger initiates capture of a single frame. Each frame requires an external trigger from the I/O connector. Camera settings, expose out behavior and sequence size is set in the software application prior to acquiring the sequence.

## Expose Out Behaviors

The settable Expose out behaviors provide flexibility in different experimental scenarios. *Note: All timing diagrams below are shown with Edge triggering mode*

### Any Row

The “Expose Out” I/O signal leaving the camera is high when any row in a single frame is exposing. The length of the Expose Out signal is equal to the time between the start of the first row’s exposure and the end of the last row’s exposure. Each line exposes for the same amount of time which is equal to what is set in the software application. Maximum camera frame rates are not possible in this mode but this does avoid frame overlap.

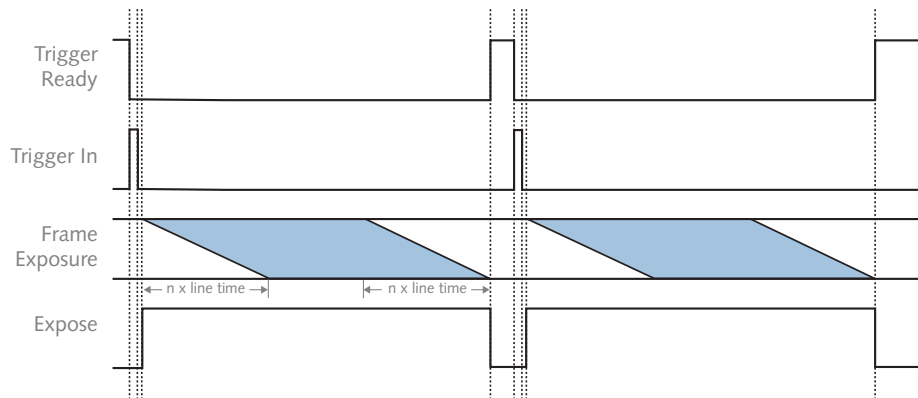

### All Rows

The “Expose Out” I/O signal leaving the camera is high only when all rows within a single frame are exposing simultaneously. The length of the Expose Out signal is equal to the time between the start of the last row's exposure and the end of the first row's exposure, which is also equal to the exposure time set in the software application. Each row exposes for the length of time as defined by the software application plus the time required for each row to start exposing (approximately 10ms).

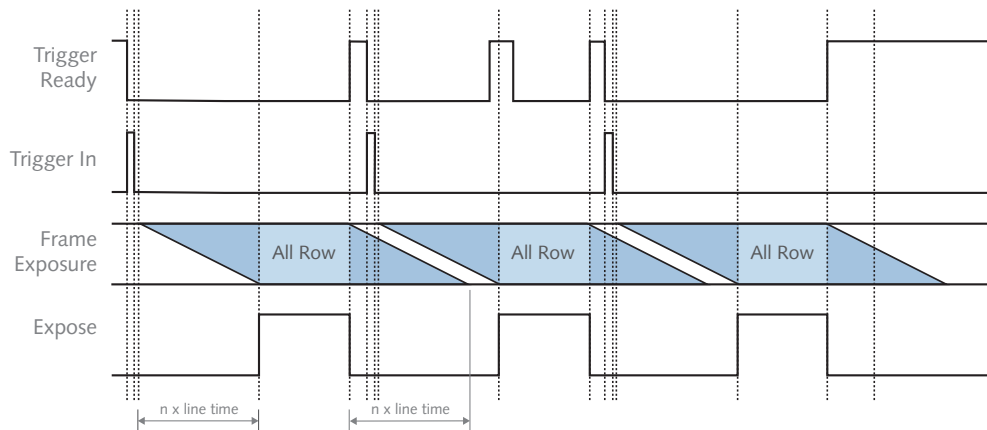

All Rows provides an effective global shutter with the speed and low noise benefits of rolling shutter, but eliminates rolling shutter motion artifacts. This mode is recommended for synchronizing the camera with high speed light sources that alternate excitation wavelengths for high speed multi-channel fluorescence. In this mode, user defined exposure time + 10ms defines camera frame rate.

The following conditions may be defined for each expose out behavior:

	First Row Expose	Any Row Expose	All Row Expose
Expose ≤ Frame Time	Yes	Yes	No
Expose > Frame Time	Yes	Yes	Yes
32fps (Full Frame)	Yes	No	Yes
Exposure Overlap	Yes	No	Yes
Simulated Global Shutter	No	No	Yes

### Rolling Shutter

Rolling shutter mode takes all rows that have been taken simultaneously so as to capture an image at an instant. The expose out signal length is equal to the time between the start of the second row and the end of the first row's exposure, which is the shortest expose out time.

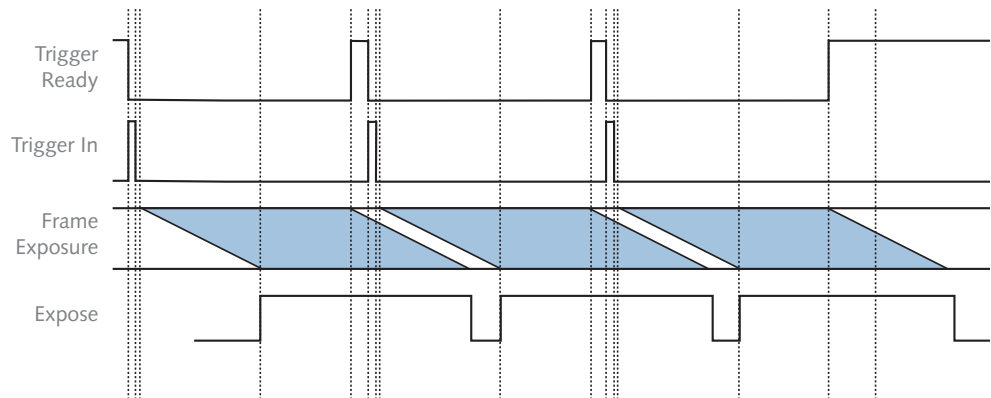

In the exposure and readout signal tracing would result in an expose out signal equal to the exposure time set in the application minus the frame readout. Each row is exposed for the exposure time minus the time required for each row to start exposing.

### First Row

In this mode the “expose out” signal length is equal to the time between the start of the first row’s exposure and the end of the first row’s exposure. For both first row and all rows mode, the expose out signal will equal to the exposure time set in the API

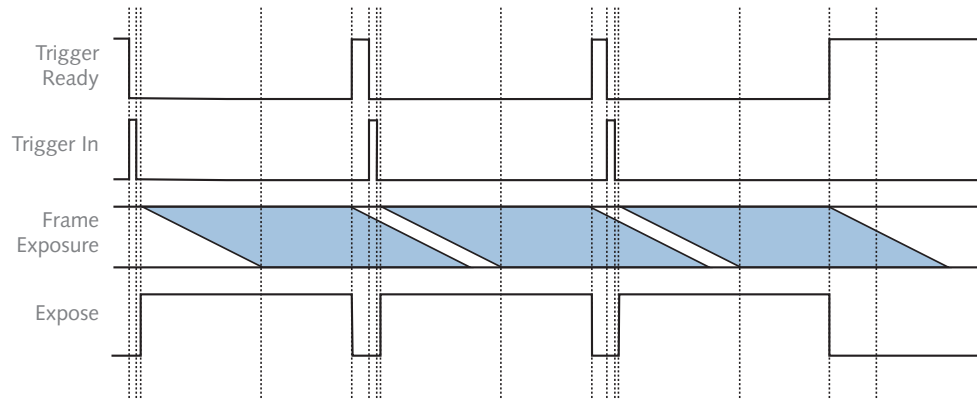

## SMART Streaming

Sequenced Multiple Acquisition Real Time Streaming, aka SMART Streaming, is an exclusive Photometrics camera feature that enables Iris to capture a continuous sequence of images, while cycling through a maximum of 16 pre-programmed exposure time values. This avoids the overhead of host communication time, resulting in very high frame rate imaging while maintaining the correct exposure level for each fluorophore.

The maximum exposure time per frame is 10 seconds in keeping with the SMART Streaming high frame rate benefits.

When Multiple Output Triggers is combined with SMART streaming, it is possible to control the exposure time of each output independently. This is much faster than using software-based methods for control timing of illumination devices.

## Cooling

Iris solves the problem of sensor and electronics cooling in two ways. First, a new, innovative fan mounting system was developed that isolates fan vibration from the rest of the camera. Side by side testing with competing products indicated that Iris outperforms alternatives in terms of vibration isolation.

With its combined TEC and forced air cooling design, the Iris the fan speed, the lower the vibration transferred. Iris provides three fan speeds, and even on the lowest setting, it can still reach nominal 0° sensor cooling in a 23° ambient.

## Advanced Features

The ideas behind two of Iris's unique signal processing capabilities are described in Chapter 3, Theory of Operation.



## Chapter 5.

# Troubleshooting

**For difficulty in troubleshooting or if the symptoms are not listed here, contact Photometrics Customer Service.**

### System Does Not Boot Normally

If the operating system does not boot normally after the interface card is installed, try reseating the PCIe card. If this is unsuccessful, try installing the new card in another open PCIe 4x or higher slot. If this does not work:

1. Turn off the computer and remove the newly installed interface card.
2. Turn the computer on. If the system boots normally, there is probably an interrupt conflict between a previously installed device

If you need assistance resolving the interrupt conflict, contact Photometrics Customer Service.

### New Hardware Found Dialog Box Does Not Appear

If the New Hardware Found dialog box does not appear after installing a new interface card to the computer and booting Windows 7:

1. Make sure the new interface card is inserted in an expansion slot according to the computer manufacturer's instructions
2. Ensure Iris is connected and powered on at least 10 seconds before starting the computer when using the PCIe interface.
3. When using the USB3.0 interface, wait for the LED on the rear of the camera to stop blinking before checking for "New Hardware Found" and opening the application.

It is possible that there is a conflict between the new interface card and a previously installed expansion card. With the computer's power turned off, remove any previously installed expansion cards that the system does not need to function (If you are unsure which cards can be safely removed, call Photometrics Customer Service.). Then turn the computer back on.

If the New Hardware Found dialog box still does not appear, contact Photometrics Customer Service.

## **Images Not Displayed**

If no images appear:

1. Confirm the camera switch is set to on.
2. Confirm that the Iris Scientific CMOS camera is selected in the imaging software application.
3. Power off the camera and the host computer and check all system connections (particularly the DATA and power cables), then restart.
4. 4. Confirm the camera is operational by taking an image with a standard C-mount (Iris 9) / F-mount (Iris 15 ) lens attached to the camera. Using normal room lighting, place the camera on a table about three meters away from an object and acquire an image.

If the problem persists, contact Photometrics Customer Service.

## **Camera Running Too Warm**

It is normal for the camera to be slightly warm to the touch while in operation. Make sure that airflow through the heat exchanger is not obstructed by the placement of the camera on a surface. If it is more than slightly warm to the touch (and at least one inch of space has been left around the cooling mechanism), switch off the camera immediately and contact Photometrics Customer Service.

## **PVCAM Error Message Appears**

If a PVCAM error message appears, note the message's number code and contact Photometrics Customer Service.

## **Lengthy Pauses During Imaging**

If you notice lengthy pauses marked by a lot of disk activity while imaging:

- Close any other programs that may be running.
- Install more physical memory (RAM) in your computer system.

**Chapter 6.**

**Basic Specifications**

**Iris Scientific CMOS:  
Front, Side And Rear Views**

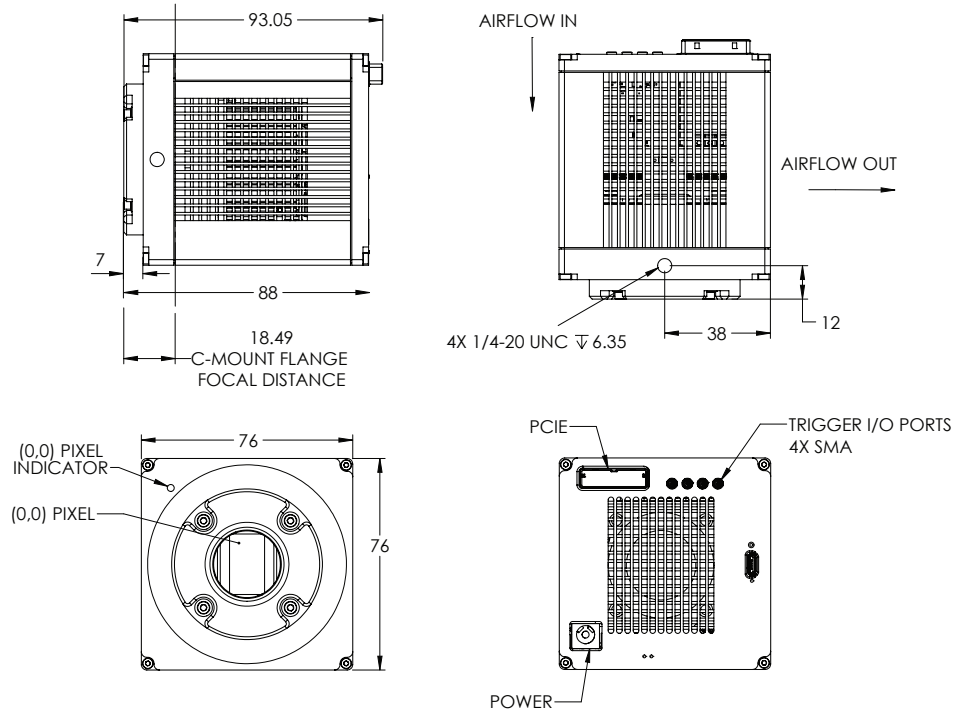

**Camera Weight**

Weight: 1.5lbs., 0.68kg

**Sensor Specifications**

Window	UV grade fused-silica Broadband MgF2 anti-reflective coating on both surfaces
Scientific CMOS sensor Array	
Sensor	GPixel GSense 5130 Scientific CMOS sensor
Sensor Process	Microlens array
Resolution (Iris 9)	2960 x 2960 (9 Megapixel)
Resolution (Iris 15)	5056 x 2960 (15 Megapixel)
Pixel Size (Iris 9)	4.25µm x 4.25µm
Pixel size (Iris 15)	4.25 µm x 4.25 µm
Digitization (Readout) Rate	480 MHz

## Power Supply Specifications

Voltage Input:	100-240 V~ @ 50-60 Hz
Current Input:	5 A (110V nominal)
Voltage Output:	+12V @ 8 A
Maximum Power Output:	140 W
Supply Cable Length:	4 ft. / 1.22 m
Certifications:	CE, UL, CUL, FCC, PSE Efficiency level VI

**Note:** CE certification applies to the Iris camera only when the camera system operates with a CE-approved power supply



**PHOTOMETRICS**<sup>®</sup>  
Scientific CMOS, EMCCD and CCD Cameras

[www.photometrics.com](http://www.photometrics.com)

Main Phone: +1 520.889.9933

Support: +1 604.530.5800 / +1 800.874.9789