



Large Field of View Scientific CMOS

Iris 15 Scientific CMOS camera is designed with a large field of view for live cell microscopy applications. Iris 15 delivers a 15 Megapixel sensor with a 25 millimeter field of view ensuring it can maximize the number of cells captured in a single frame. Iris 15 is equipped with an imaging area that is 50% larger than current sCMOS devices.

The 4.25µm pixels provide highly detailed images across the imaging plane and allow for Nyquist spatial sampling at 40X magnification. The camera can capture dynamic cellular events at 30 frames per second for the full frame, and at thousands of frames per second with regions.

The Iris 15 has a high quantum efficiency and low noise levels to maximize dim signal detection and allowing for the use of shorter exposure times to minimize cellular photo-damage.

The Iris 15 is the ideal camera to leverage the larger fields of view of newer microscopes and to image with high frame rates with high resolution for live-cell microscopy applications.

Primary applications:

- Light Sheet Microscopy
- Multi-Color Fluorescence
- High Content Screening
- Tiling Applications

- ▶ 15 Megapixel (5056 x 2960)
- ▶ 25mm Field of View
- ▶ 4.25µm x 4.25µm Pixel Area
- ▶ 30 Frames per Second
- ▶ 73% Quantum Efficiency

Features	Advantages
15 Megapixel Sensor 25mm Field of View	Maximize the imaging area and increase the number of cells acquired per frame
Optimized 4.25µm Pixel Size	Image the finer details of your samples and maintain proper spatial sampling at 40X magnification
Fast Frame Rates	Capture dynamic cellular events with high temporal resolution
High Quantum Efficiency	Maximizes the ability to detect signals, enables shorter exposure times and minimizes photo-toxicity
Low Read Noise	Maximize ability to detect extremely faint fluorescence signals
Large Dynamic Range	Measure both bright and dim signal levels within the same image

Specifications	Camera Performance
Sensor	GPixel GSense 5130 Scientific CMOS sensor
Active Array Size	5056 x 2960 (15 Megapixel)
Pixel Area	4.25µm x 4.25µm (18.06µm ²)
Sensor Area	21.49mm x 12.61mm 24.9mm diagonal
Peak QE%	>73%
Read Noise	1.5e-
Full-Well Capacity	13,000e-
Bit Depth	16-bit
Readout Mode	Rolling Shutter Effective Global Shutter
Binning	2x2 (on FPGA)

Cooling Performance	Sensor Temperature	Dark Current
Air Cooled	0°C @ 30°C Ambient	0.5e-/pixel/second

Specifications	Camera Interface
Digital Interface	PCIe
Lens Interface	F-Mount
Mounting Points	¼ 20" mounting point on each side

Triggering Mode	Function
Input Trigger Modes	Trigger-First: Sequence triggered on first rising edge Edge: Each frame triggered on rising edge
Output Trigger Modes	Any Row: Expose signal is high while any row is acquiring data All Rows: Effective Global Shutter – Expose signal is high when all rows are acquiring data Signal is high for set Exposure time Rolling Shutter: Effective Global Shutter – Expose signal is high when all rows are acquiring data Signal is High for set Exposure time – Readout Time
Output Trigger Signals	Expose Out, Read Out, Trigger Ready

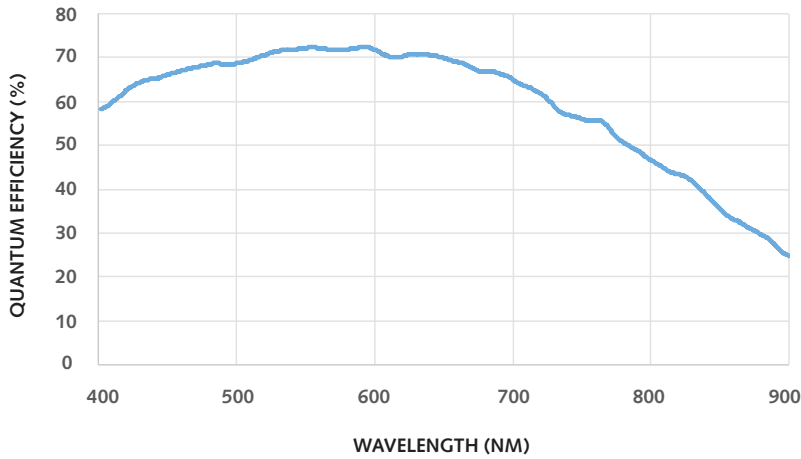

Frame Rate (PCIe interface)	
Array Size	16-bit
5056 x 2960	30
5056 x 1500	59
5056 x 512	174
5056 x 128	695

Accessories (Included)	
PCIe Card/Cable	Manual
Trigger Cable	QuickStart Guide
Power Supply	

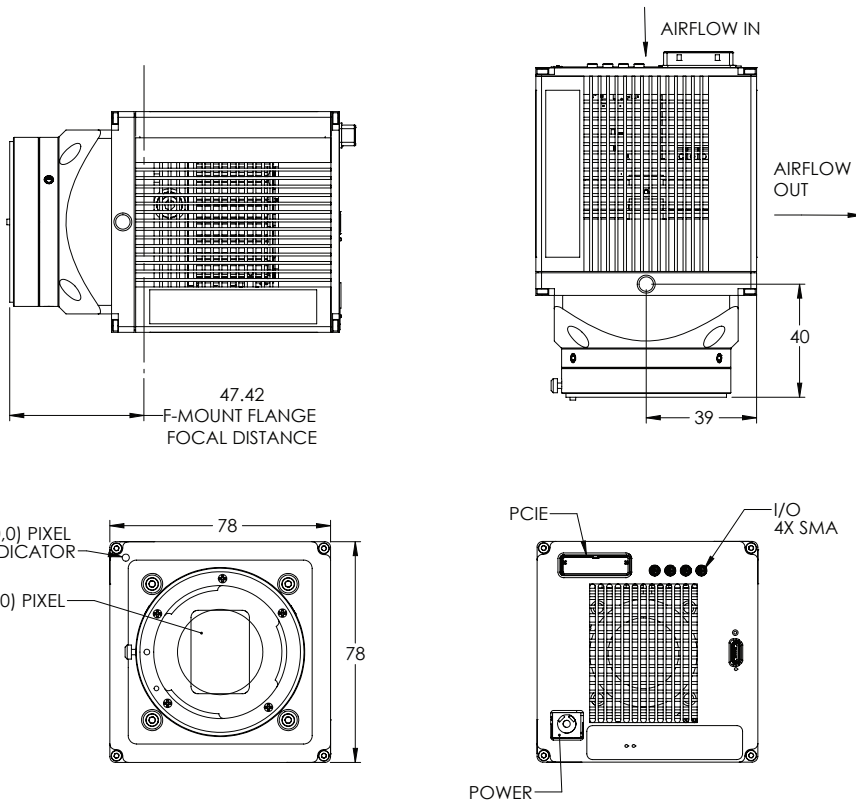

Photometrics is a registered trademark.
 Iris 15 is a trademark of Photometrics.
 All other brand and product names are the trademarks of their respective owners.

Specifications in this datasheet are subject to change.

Refer to the Photometrics website for most current specifications.

PHOTOMETRICS
www.photometrics.com
 info@photometrics.com
 tel: +1 520.889.9933