



Large Field of View BSI Scientific CMOS

Discovery depends on every photon

The Prime 95B 22mm delivers a large imaging area and combines this with the near-perfect sensitivity of a Backside Illuminated (BSI) Scientific CMOS sensor. The Prime 95B 22mm sensor converts up to 95% of incident photons into measurable signal, and provides a large 22mm field of view. The Prime 95B 22mm is optimally positioned to maximize detection and imaging throughput on larger format microscopes.

The extreme sensitivity not only allows fainter signals to be detected, it provides the flexibility to increase frame rates, or turn down the excitation intensity to reduce cellular photo-damage. The Prime 95B 22mm improves the field of view and maintains the high frame rates and extremely low read noise that has made sCMOS so popular for live-cell imaging.

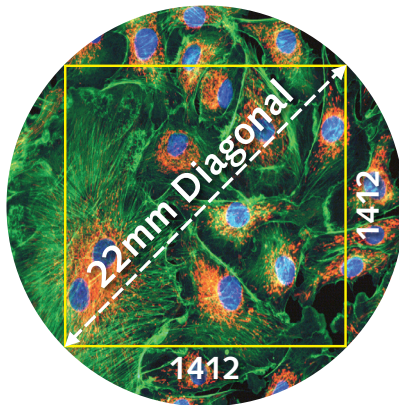

- ▶ 95% Quantum Efficiency
- ▶ 22mm Field of View (1412x1412)
- ▶ 1.6e- Read Noise (median)
- ▶ 35fps @ 16-bit / 70 fps @ 12-bit

Features	Advantages
High Quantum Efficiency 95% Peak QE	Maximizes ability to detect weak signals, enables short exposure times for high frame rates, minimizes phototoxicity across a wide range of wavelengths
Large 22mm Field of View	Maximize imaging area and increase throughput
Large 11µm Pixel Size	Maximize light collection while maintaining proper spatial sampling
Extremely Low Read Noise	Maximize your ability to detect faint fluorescence
Fast Frame Rates	Capture highly dynamic events with high temporal resolution
Enhanced Dynamic Range	Measure both bright and dim signal levels within the same image 50,000:1 Dynamic Range (94 dB)
Multiple Expose Out Triggering	Control up to four light sources for multi-wavelength acquisitions
SMART Streaming	Faster acquisition rates with variable exposures, ideal for multi-probed live cell imaging Compatible with Multiple Expose Out Triggering

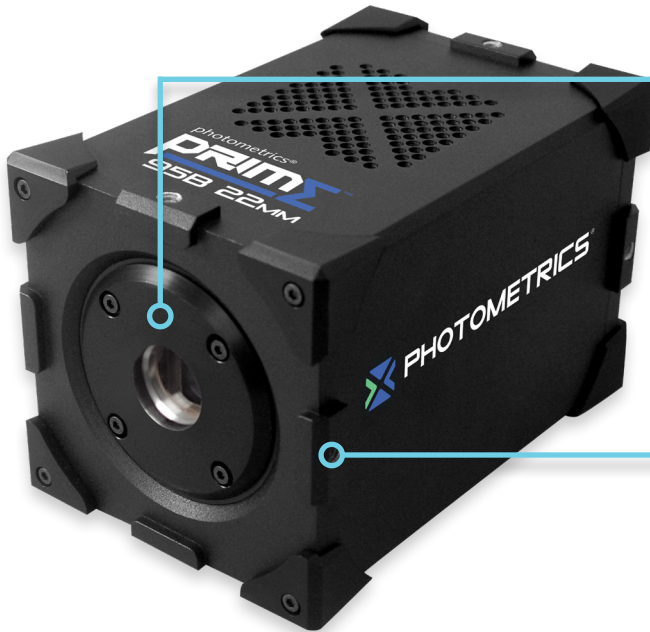

2.0 Megapixel BSI CMOS Sensor

Backside Illuminated Sensor
 1.6e- Read Noise (Median)
 >95% peak QE
 80,000e- full well
 11 x 11µm pixels
 22mm diagonal

Easily Mounted and Secured

C-mount
 Two ¼"-20 mounting holes per side

Convenient Interface

- 16-bit Data
 - 35fps
- 12-bit Data
 - 70fps

Multiple Cooling Options

- Forced Air Cooling
 - -20°C Cooling
 - Selectable Fan Speed
- Liquid Cooling
 - -25°C Cooling
 - Leak-proof, quick-disconnect ports



Advanced Application Triggers

Effective Global Shutter
 Up to four selectable expose-out lines

Specifications	Camera Performance
Sensor	GPixel GSense 400 BSI CMOS Gen IV, Grade 1 in imaging area
Active Array Size	1412 x 1412 (2.0 Megapixel)
Pixel Area	11µm x 11µm (121µm ²)
Sensor Area	15.5mm x 15.5mm 22mm diagonal
Peak QE%	>95%
Read Noise	1.6e- (Median) 1.8e- (RMS)
Full-Well Capacity	80,000e-
Dynamic Range	50,000:1
Bit Depth	16-bit, 12-bit
Readout Mode	Rolling Shutter Effective Global Shutter
Binning	2x2 (on FPGA)

Cooling Performance	Sensor Temperature	Dark Current
Air Cooled	-20°C @ 25°C Ambient	0.55e-/pixel/second
Liquid Cooled	-25°C @ 25°C Ambient	0.3e-/pixel/second

Specifications	Camera Interface
Digital Interface	PCI-E, USB 3.0
Lens Interface	C-Mount
Mounting Points	2 x ¼ 20" mounting points per side to prevent rotation
Liquid Cooling	Quick Disconnect Ports

Triggering Mode	Function
Input Trigger Modes	Trigger-First – Sequence triggered on first rising edge Edge – Each frame triggered on rising edge SMART Streaming – Fast iteration through multiple exposure times
Output Trigger Modes	First Row – Expose signal is high while first row is acquiring data Any Row – Expose signal is high while any row is acquiring data All Rows – Effective Global Shutter – Expose signal is high when all rows are acquiring data
Output Trigger Signals	Expose Out (up to four signals), Read Out, Trigger Ready

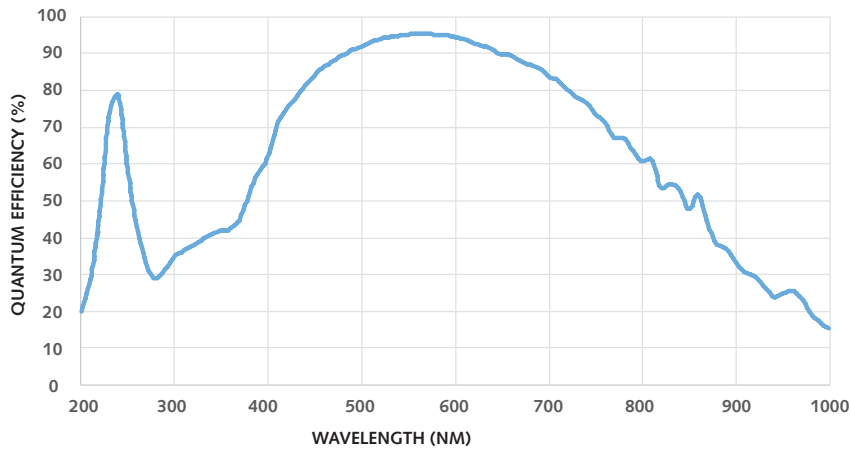

Frame Rate (PCIe interface)		
Array Size	16-bit	12-bit
1412x1412	35	70
1412x1200	41	82
1412x512	96	192
1412x256	192	384
1412x128	384	736

Accessories (Included)	
PCIe Card/Cable	Power Supply
USB 3.0 Cable	Manuals and QuickStart Guide
Trigger Cable	Performance and Gain Calibration Test Data

Accessories (Additional)
Liquid Circulator
Liquid Cooling Tubes

Distance from C-mount to sensor

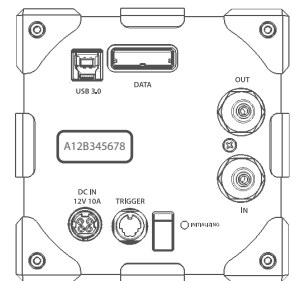
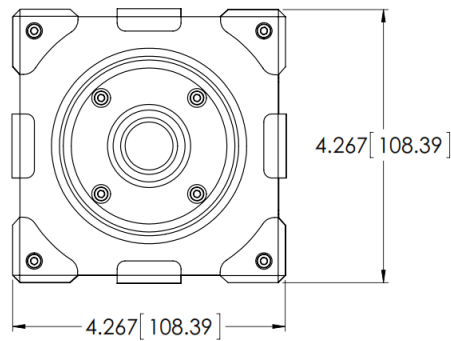
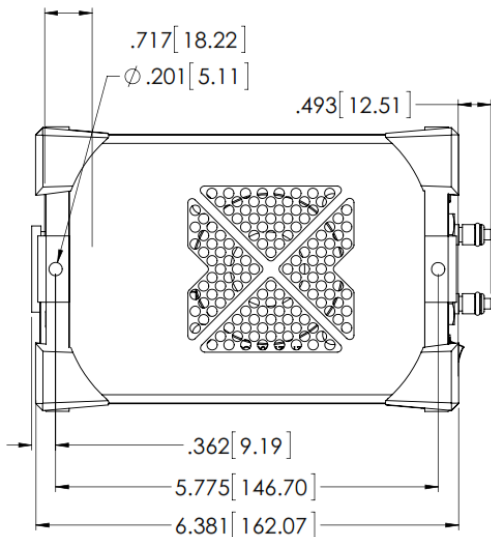

Photometrics is a registered trademark.
 Prime 95B 22mm is a trademark of Photometrics.
 All other brand and product names are the trademarks of their respective owners.

Specifications in this datasheet are subject to change.

Refer to the Photometrics website for most current specifications.

PHOTOMETRICS
www.photometrics.com
 info@photometrics.com
 tel: +1 520.889.9933