



Scientific CMOS

Neo and Zyla sCMOS Cameras
Imaging Without Compromise



Scientific CMOS (sCMOS) technology overview

Scientific CMOS (sCMOS) is a breakthrough technology that offers an advanced set of performance features that render it ideal to high fidelity, quantitative scientific measurement.

Scientific CMOS can be considered unique in its ability to simultaneously deliver on many key performance parameters, overcoming the 'mutual exclusivity' associated with current scientific imaging technology standards, and eradicating the performance drawbacks traditionally associated with CMOS imagers.

sCMOS is uniquely capable of simultaneously delivering:

- Extremely low noise
- Rapid frame rates
- Wide dynamic range
- High resolution
- Large field of view
- High Quantum Efficiency (QE)
- Rolling and Global (Snapshot) exposure modes



Neo cameras will literally allow one to see cells in a new light with ultra sensitive imaging at speeds never achieved before - as we have seen in our tests of vesicle trafficking. These scientific CMOS cameras are not a small step, but a quantum leap, that will open up new possibilities of what can be studied in fast cellular processes, rapid screening, and super-resolution imaging.



Derek Toomre, PhD.,
Associate Professor, Department of Cell Biology,
Yale University School of Medicine



See page 30 for
'Comparing sCMOS with
other detectors'
technical note

sCMOS - Imaging without compromise

The 5.5 megapixel sensor offers a large field of view and high resolution, without compromising read noise, dynamic range or frame rate. Rolling and Global (Snapshot) shutter readout ensure maximum application flexibility.

Read noise is exceptional, even when compared to the highest performance 'slow-scan' CCDs. The fact that an sCMOS device can achieve 1 electron rms read noise while reading out 5.5 megapixels at 30 fps renders it truly extraordinary in the market. Furthermore, the sensor is capable of achieving 100 full fps with a read noise 1.3 electrons rms. By way of comparison, the lowest noise Interline CCD, reading out only 1.4 megapixels at ~ 16 fps would do so with ~ 10 electrons read noise.

The low noise readout is complemented by up to 30,000:1 dynamic range. Usually, for CCDs or EMCCDs to reach their highest dynamic range values, there needs to be a significant compromise in readout speed, yet sCMOS can achieve this value while delivering high frame rates. The unique dual amplifier architecture of sCMOS allows for high dynamic range by offering a large well depth, despite the relatively small 6.5 μm pixel size, alongside lowest noise. A 1.4 megapixel Interline CCD with similarly small pixels achieves only ~1,800:1 dynamic range at 16 fps.

Parameter	sCMOS (Neo)	Interline CCD	EMCCD
Sensor Format	5.5 megapixel	1.4 to 4 megapixel	0.25 to 1 megapixel
Pixel Size	6.5 μm	6.45 to 7.4 μm	8 to 16 μm
Read Noise	1 e ⁻ @ 30 fps 1.3 e ⁻ @ 100 fps	4 - 10 e ⁻	< 1e ⁻ (with EM gain)
Full Frame Rate (max.)	Sustained: 30 fps full frame Burst: 100 fps full frame	3 to 16 fps	~ 30 fps
Quantum Efficiency (max.)	57%	60%	90% 'back-illuminated' 65% 'virtual phase'
Dynamic Range	30,000:1 (@ 30 fps)	~ 3,000:1 (@ 11 fps)	8,500:1 (@ 30 fps with low EM gain)
Multiplicative Noise	None	None	1.41x with EM gain

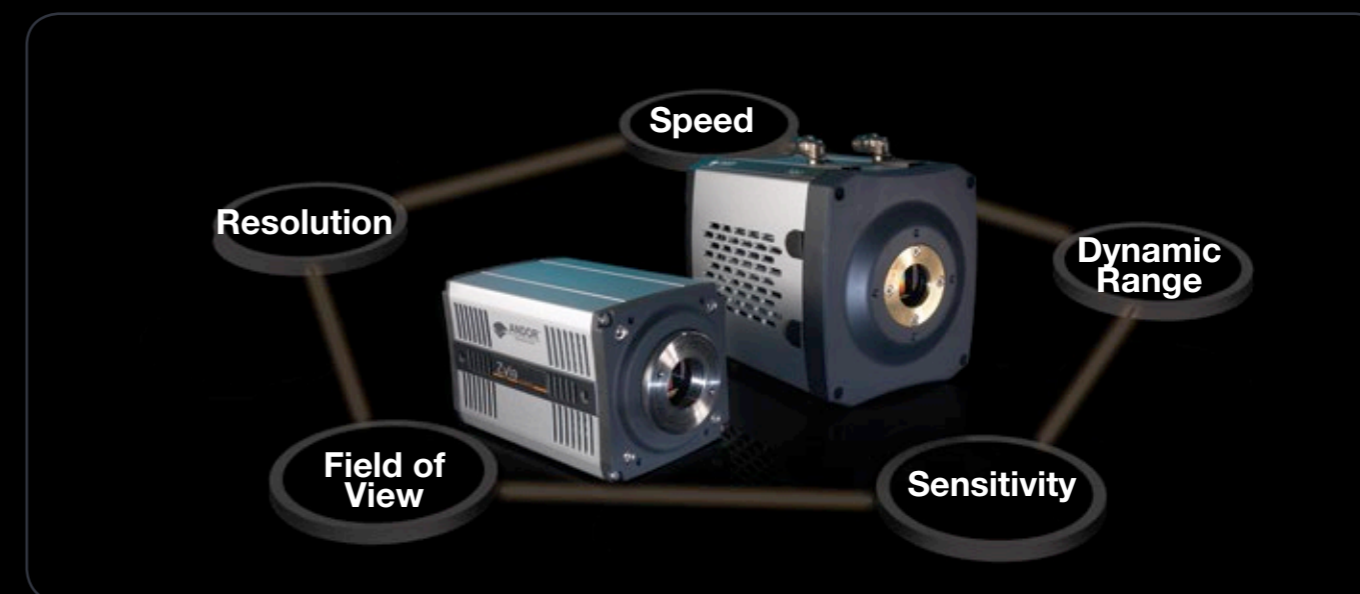

Neo sCMOS

Andor's Neo sCMOS vacuum cooled camera platform has been engineered from the ground up, specifically to realize the absolute highest sensitivity from this exciting new sensor technology.

Neo breaks new boundaries in offering an exceptionally low noise floor of 1 e⁻ rms without the need for signal amplification technology, uniquely coupled in Neo to a dynamic range of up to 30,000:1. Speeds of 30 fps (full frame) can be maintained over extended kinetic series acquisitions, with 100 fps achievable in burst mode.

Neo offers an advanced set of unique performance features and innovations, including deep vacuum TE cooling to -40°C, extensive 'on-head' FPGA data processing capability, a 4 GB memory buffer and a Data Flow Monitor. Andor's UltraVac™ vacuum process has been implemented to offer not only the necessary deep cooling capability, but also complete protection of the sensor. These capabilities have been conceptualized to drive best possible performance, image quality and longevity from sCMOS technology.

Neo offers both Rolling and Global (also known as 'Snapshot') Shutter exposure mechanisms. Snapshot mode provides an exposure sequence that is analogous to that of an interline CCD, whereby all pixels begin the exposure simultaneously and end the exposure simultaneously.

- -40°C vacuum cooling
- Rolling and Snapshot exposure
- Vacuum longevity
- Blemish minimization
- 4 GB on-head memory
- 5.5 Megapixel
- 1 e⁻ noise
- 30 fps / 100 fps burst
- 30,000:1 dynamic range
- Superior image quality
- Quantitative stability
- Vibration free fan off mode
- Fast exposure switching
- Data Flow Monitor



Features

TE cooling to -40°C

Rolling and Global (Snapshot) shutter

1 e⁻ read noise

5.5 megapixel sensor format and 6.5 μm pixels

Rapid frame rates

UltraVac™

Dual-Gain amplifiers

4 GB on-head image buffer

High Quantum Efficiency

Extensive FPGA on-head data processing

Hardware timestamp

Dynamic baseline clamp

Spurious noise filter

Single window design

Data Flow Monitor

iCam

Comprehensive trigger modes and I/O

Camera Link

Benefits

Minimization of dark current to maintain low noise advantage under all exposure conditions. Minimization of hot pixel blemishes meaning more useful pixels. Fan-off mode for vibration sensitive set-ups

Maximum exposure and readout flexibility across all applications. Snapshot for 'interline CCD' exposure capability

Offers lower detection limit than any CCD

Delivers extremely sharp resolution over a 22 mm diagonal field of view: ideal for cell microscopy and astronomy

>30 fps over extended kinetic series. Burst to memory at 100 fps full frame

Sustained vacuum integrity and unequalled cooling with 5 year warranty; complete sensor protection

Maximum well depth and lowest noise simultaneously, affording extended dynamic range of 30,000:1

Enables bursts of 100 fps @ full dynamic range. Capture extended kinetic series faster than PC write speed, avoiding prohibitively expensive PCs

Optimized for popular green/red emitting fluorophores

Essential to ensure best image quality and quantitative fidelity from sCMOS technology

FPGA generated timestamp with 25 ns accuracy

Essential to ensure quantitative accuracy across the image area and between successive images of a kinetic series

Realtime FPGA filter that identifies and compensates for spurious high noise pixels

Single input window with double AR coating ensures maximum photon throughput

Innovatively manage acquisition capture rates vs data bandwidth limitations

Market leading fast exposure switching with minimal overheads

Communication and synchronization within intricate experimental set-ups

Camera Link interface permits high bandwidth data spooling to PC, allowing fast continuous kinetic series

Key Specifications

Active Pixels	2560 x 2160
Pixel Size (W x H; μm)	6.5 x 6.5
Sensor size (mm)	16.6 x 14
Read Noise (e ⁻)	1 @ 200 MHz 1.3 @ 560 MHz
Sensor Cooling	-40°C
Pixel Well Depth (e ⁻)	30,000
Max Readout Rate (MHz)	560 MHz (280 MHz x 2 outputs)
Max Frame Rates (fps)	Sustained: 30 fps full frame Burst: 100 fps full frame
QE max	57%

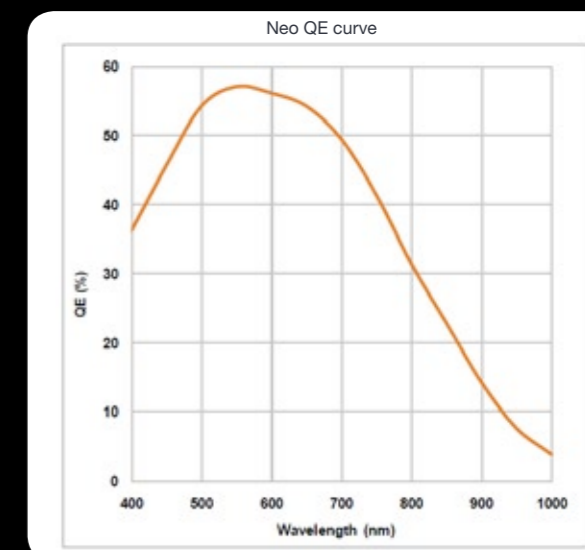

Zyla sCMOS

NEW!

Andor's new Zyla sCMOS camera offers high speed, high sensitivity imaging performance in a remarkably light and compact, TE cooled design.

Zyla is ideally suited to many cutting edge applications that push the boundaries of speed, offering sustained frame rate performance of up to 100 fps (faster with ROI). A highly cost-effective 30 fps version is also available, offering 1.2 e⁻ rms read noise, representing an ideal low light 'workhorse' camera solution for both microscopy and physical science applications, in either research or OEM environments.

Rolling and Global (Snapshot) Shutter readout ensures maximum application flexibility. Global Shutter in particular provides an important 'freeze frame' exposure mechanism that emulates that of an interline CCD, overcoming the transient readout nature of rolling shutter mode.

'Conceptualized to dramatically outperform interline CCD technology within a 'mid-range' price bracket, Andor's Zyla sCMOS is ideally placed to become the new gold standard workhorse imaging detector.'

- Compact and light
- Rolling and Snapshot exposure
- 100 fps sustained
- 1.2 e⁻ noise @ 30 fps
- 5.5 Megapixel
- Cost effective
- 0°C cooling @ up to 35°C ambient
- 25,000:1 dynamic range
- Superior image quality
- Quantitative stability
- Fast exposure switching
- Data Flow Monitor

Zyla sCMOS for OEM

The light and compact form factor coupled with design and mounting adaptability, board level or private labelling options, and unparalleled engineering support, renders the Zyla highly suited to OEM integration.

Please call Andor to discuss how Zyla can be made to work for you.



Features

Compact and light	Ideal for integration into space restrictive set-ups. Ideal for OEM
Rolling and Global (Snapshot) shutter	Maximum exposure and readout flexibility across all applications. Snapshot for 'interline CCD mode' freeze frame capture of fast moving/changing events
1.2 e ⁻ read noise	Offers lower detection limit than any CCD
100 fps sustained	'10-tap' Camera Link and high speed data processing harnesses fastest possible frame rate from sensor. Highly cost effective '3-tap' 30 fps option available
5.5 megapixel sensor format and 6.5 μm pixels	Delivers extremely sharp resolution over a 22 mm diagonal field of view: Ideal for cell microscopy and astronomy
Dual-Gain Amplifiers	Maximum well depth and lowest noise simultaneously, affording extended dynamic range of 25,000:1
TE cooling to 0°C in 35°C ambient	Ideal for OEM integration into enclosed systems
High Quantum Efficiency	Optimized for popular green / red emitting fluorophores
Extensive FPGA on-head data processing	Essential to ensure best image quality and quantitative fidelity from sCMOS technology
Hardware Timestamp	FPGA generated timestamp with 25 ns accuracy
Dynamic Baseline Clamp	Essential to ensure quantitative accuracy across the image area and between successive images of a kinetic series
Spurious Noise Filter	Real time FPGA filter that identifies and compensates for spurious high noise pixels
Single window design	Single input window with double AR coating ensures maximum photon throughput
Data Flow Monitor	Innovatively manage acquisition capture rates vs data bandwidth limitations
iCam	Market leading fast exposure switching with minimal overheads
Comprehensive trigger modes and I/O	Communication and synchronization within intricate experimental set-ups
Camera Link	Camera Link interface permits high bandwidth data spooling to PC, allowing fast continuous kinetic series

Benefits

Key Specifications

Active Pixels	2560 x 2160
Pixel Size (W x H; μm)	6.5 x 6.5
Sensor size (mm)	16.6 x 14
Read Noise (e ⁻)	1 @ 200 MHz 1.45 @ 560 MHz
Sensor Cooling	0°C (up to +35°C ambient)
Pixel Well Depth (e ⁻)	30,000
Max Readout Rate (MHz)	560 MHz (280 MHz x 2 outputs)
Max Frame Rates (fps)	Sustained: 100 fps full frame
QE max	57%

Zyla QE curve

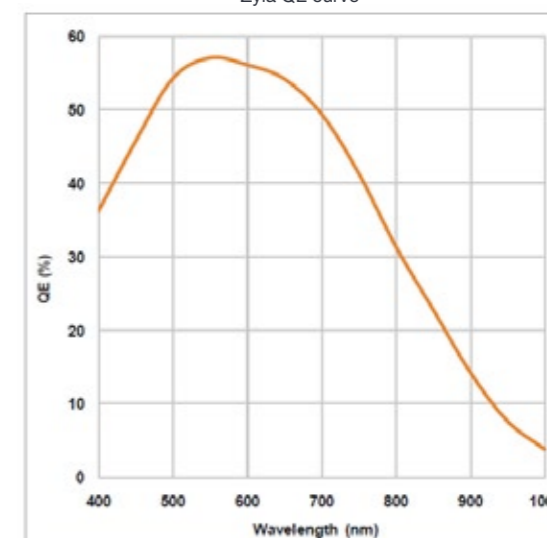

Performance and Innovations

Extended Dynamic Range

The Andor Neo and Zyla cameras are designed to make use of the innovative dual 'column-level' amplifier design of the sensor.

Traditionally, sensors require that the user must select up-front between high or low amplifier gain (i.e. sensitivity) settings, depending on whether they want to optimize for low noise or maximum well depth. The dual amplifier architecture of the sCMOS sensor circumvents this need, in that signal can be sampled simultaneously by both high and low gain amplifiers. As such, the lowest noise of the chip can be harnessed alongside the maximum well depth, affording widest possible dynamic range of up to 30,000:1.

Dual Amplifier Architecture:

Each column within each half of the sensor is equipped with dual column level amplifiers and dual analog-to-digital converters (ADC).

This architecture was designed to simultaneously minimize read noise and maximize dynamic range. The dual column level amplifier/ADC pairs have independent gain settings, and the final image is reconstructed by combining pixel readings from both the high gain and low gain readout channels to achieve an unprecedented intra-scene dynamic range from the relatively small 6.5 μm pixel pitch.



See page 24 for 'Dual Amplifier Dynamic Range' technical note

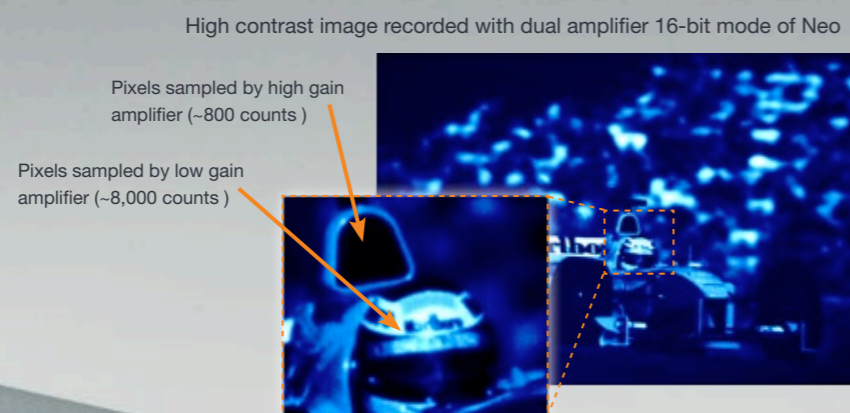

Lowest Noise Floor

Andor's ultra sensitive sCMOS cameras have broken new ground in offering an unparalleled 1 electron rms read noise floor, without amplification technology.

What is truly extraordinary is that this performance level is achievable at 30 fps, representing 200 MHz pixel readout speed. Furthermore, even at full readout speed, the read noise floor is negligibly compromised, maintaining down to 1.3 e^- rms at 100 fps. For the best CCD cameras to even approach 2 electrons noise, a readout speed of 1 MHz or slower is required. This minimal detection limit renders Andor's sCMOS cameras suitable for a wide variety of challenging low light imaging applications.

Readout Speed (MHz)	Neo Readout Noise (e^-)	
	Rolling Shutter	Global Shutter
200 MHz	1	2.3
560 MHz	1.3	2.5



See page 39 for 'Understanding Read Noise' technical note

(a)

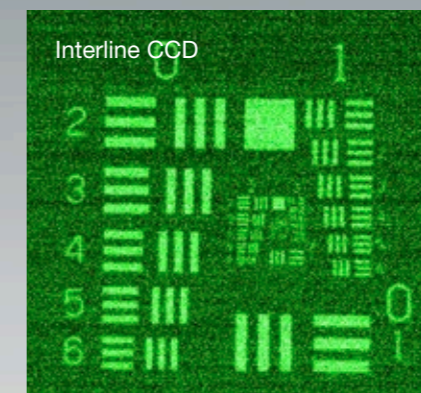
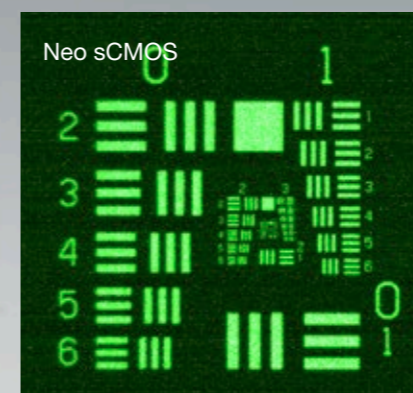

Comparative low light images taken with Neo sCMOS (1.3 electrons read noise @ 560 MHz) vs. Interline CCD (5 electrons read noise @ 20 MHz), displayed with same relative intensity scaling.

(a) LED signal in a light-tight imaging enclosure, intensity ~ 30 photons/pixel; (b) Fluorescently labelled fixed cell using a CSU-X spinning disk confocal microscope (x60 oil objective), each 100 ms exposure, same laser power,

(b)

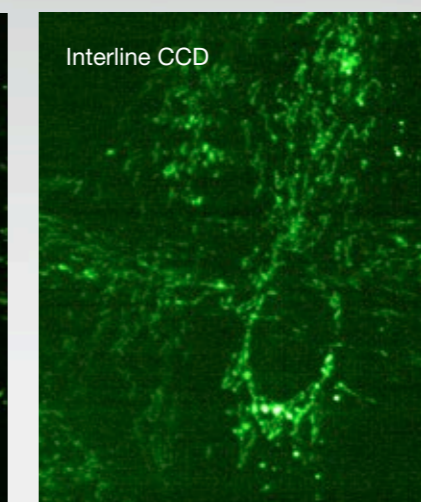
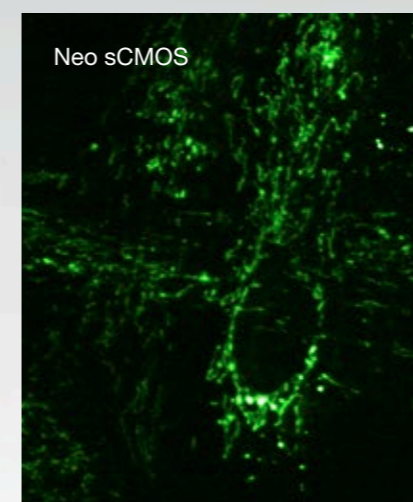

Spurious Noise Filter

Neo and Zyla both come equipped with an optional in-built FPGA filter that operates in realtime to reduce the frequency of the occurrence of high noise pixels that would otherwise would appear as spurious 'salt and pepper' noise spikes in the image background.

Performance and Innovations

Rapid Frame Rates

The parallel readout nature of sCMOS means it is capable of reaching very rapid frame rates of up to 100 full frames per second, and much faster with region of interest.

Distinctively, this is accomplished without significantly sacrificing read noise performance, markedly distinguishing the technology from CCDs. Andor's sCMOS cameras are uniquely designed to harness this speed potential.

Array Size	Camera Link 3-tap		Camera Link 10-tap	
	Rolling Shutter	Global Shutter	Rolling Shutter	Global Shutter
2560 x 2160 (full frame)	30	30	100	50
2064 x 2048	39	39	105	52
1392 x 1040	80	80	198	97
512 x 512	420	201	420	201
128 x 128	1,662	736	1,662	736

Maximum frame rates achievable from the Zyla sCMOS (3-tap and 10-tap Camera Link options available)

Neo 4 GB on-head memory

Neo is the only scientific CMOS camera on the market with on-head memory. This renders it unique in its ability to acquire bursts of uncompressed data at the full 100 fps with 16-bit digitization.

Neo 4 GB on-head memory can also be used to perform extended kinetic series that are faster than the write rate of a hard drive (or other 3rd party software induced bottleneck). For example, data can be captured at 40 fps but the hard drive could be restricted to writing at 20 fps. Thus the on-head memory buffer will fill at a rate of 20 fps. Such flexibility can be useful as PC performance is notoriously variable.

iCam fast exposure switching

Neo and Zyla benefit from Andor's iCam technology, an innovation that ensures minimal overheads associated with fast exposure switching.

This is particularly important during multi-color microscopy acquisition protocols, whereby it is necessary to repeatedly and rapidly flip between pre-set exposure times matched to the relative signal intensity of each fluorophore.

iCam offers market leading acquisition efficiency, whether software or externally triggered.

“

Our experiments with Andor's new sCMOS camera have been highly encouraging. The combination of very low noise sensitivity at rapid frame rates, coupled with high pixel resolution and large dynamic range, will enable us to investigate single molecules at timescales which were previously not accessible.

”



Prof. Stefan Diez
Heisenberg Professorship for BioNanoTools
Max Planck Institute of Molecular Cell Biology and Genetics, Dresden

Data Flow Monitor

The sCMOS sensor in Neo and Zyla is capable of extremely fast data read rates, but this in itself imposes considerable challenges.

For sustained kinetic series measurements it is possible to be rate limited by:

(a) bandwidth of the Camera Link interface connecting the camera to the PC

(b) hard drive write speed

In such circumstances the true frame rate threshold also depends on many set-up factors, including exposure time, ROI size, binning, pixel readout rate and choice of single or dual amplifier data.

The Data Flow Monitor has been innovated to provide a simple visual tool that enables you to instantly ascertain if your acquisition parameters will result in a rate of data transfer that is too fast for either interface or hard drive. It will also determine if the kinetic series size is within the capacity of camera memory, hard drive space or PC RAM.

The Data Flow Monitor can be regarded as an essential tool for day-to-day usage of sCMOS technology.

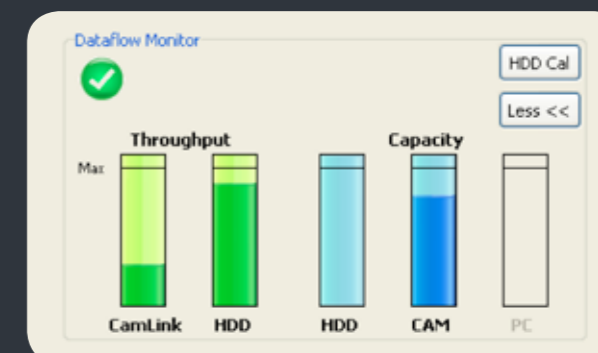

e.g. 1 - Requested kinetic series within capability of Camera Link data transfer bandwidth and Hard Disk Drive write speed.

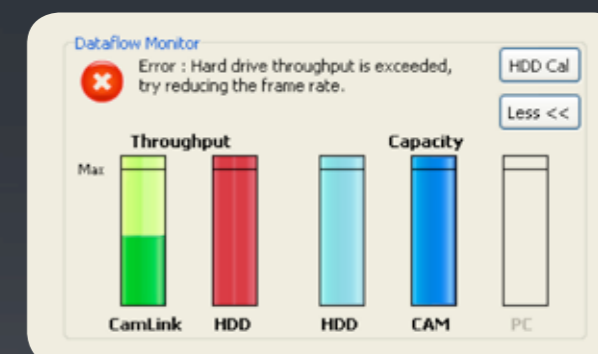

e.g. 2 - Hard Disk Drive will not write data fast enough for the requested kinetic series. Advised to first reduce data rate.



Performance and Innovations

Deep Thermoelectric Cooling

Andor's Neo offers the deepest sensor cooling available from any CMOS imaging camera on the market, minimizing both darkcurrent and hot pixel blemishes. Additionally, through use of water cooling, the fan can be switched off in the software to minimize camera vibration, ideal for set-ups that are particularly vibration sensitive.

Neo Cooling Temperature	Darkcurrent
-30°C (fan cooling)	0.07 e ⁻ /pixel/sec
-40°C (10°C liquid)	0.03 e ⁻ /pixel/sec

Deep TE cooling is useful for a number of reasons:

Minimization of darkcurrent

sCMOS cannot be considered a truly flexible, workhorse camera unless darkcurrent contribution has been minimized. Deep cooling means the low noise advantage can be maintained under all exposure conditions.

Minimization of hot pixel blemishes

Hot pixels are spurious pixels with significantly higher darkcurrent than the average and can be problematic even under relatively short exposure times. Cooling has a major influence in minimizing the occurrence of such events, offering both an aesthetically cleaner image and a greater number of unfiltered, usable pixels

Minimization of vibration

Many optical configurations are sensitive to vibrations from the camera fan.

Andor's Neo offers:

- (a) Two fan speeds
- (b) Ability to turn off fan, either temporarily or permanently if flowing liquid through the camera (the latter also allows the Neo to be stabilized at -40°C)

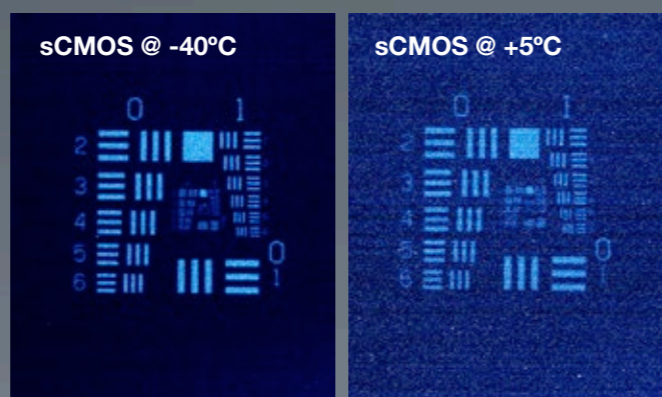

Thermal noise can sacrifice the sCMOS low detection limit. Low light images recorded with a Neo sCMOS camera at +5°C and -40°C sensor cooling temperatures; 50 sec exposure time; 200 MHz readout giving 1 electron read noise.

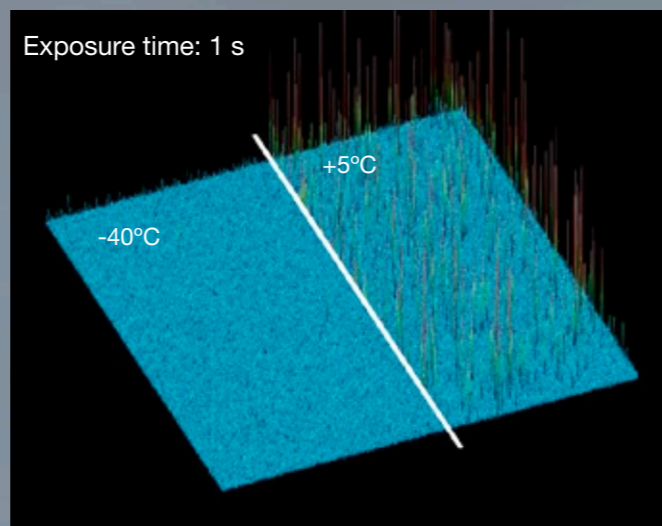

Hot pixel blemishes are significantly reduced at deeper cooling temperatures, requiring much reduced pixel correction. Uncorrected images are shown above for 1 sec exposure.

Thermostatic Precision

The temperature sensor in the Neo and Zyla sCMOS cameras measures with a thermostatic precision of 0.05°C



See page 26 for 'Importance of TE Cooling' technical note

UltraVac™ (Neo only)

The Andor Neo is the only vacuum housed CMOS sensor available on the market, offering superior quality, performance and longevity.

Andor's proprietary UltraVac™ process has a proven track record of field reliability, accumulated over more than 15 years of shipping high-end vacuum cameras. Using a proprietary technique, we have adapted these process for use with the additional connections associated with the sCMOS sensor.

- Permanent hermetic vacuum seal
- Sustained deep TE cooling
- No maintenance / re-pumping
- No risk of condensation
- Minimize out-gassing



5 Year Vacuum Warranty

Our faith in the unique sCMOS vacuum process used in Neo means that we are proud to offer an extensive 5 year warranty on the vacuum enclosure.

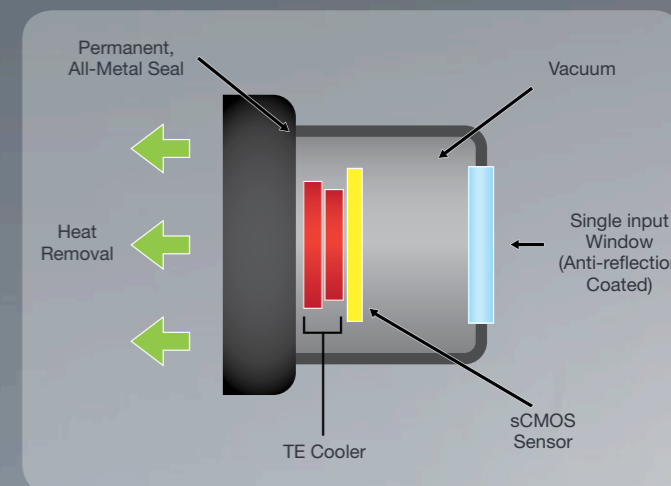

Schematic of the Neo sCMOS permanent vacuum head



Performance and Innovations

Advanced FPGA on-head processing

Andor's Neo and Zyla cameras are each equipped with considerable FPGA processing power. This is essential in order to dynamically normalize data at the pixel level for minor variations in bias offset, thus eradicating fixed pattern noise associated with this CMOS phenomenon. This superior dynamic processing capability is also utilized to optionally filter the small percentage of spurious noise pixels from the image.

Pixel-level bias offset compensation

The advanced processing power and memory capacity permits implementation of bias offset compensation for **every pixel** in the array. This ultimately relates to a lower noise background.

Dynamic baseline clamp

A real time algorithm that uses dark reference pixels on each row to stabilize the baseline (bias) offset. Necessary to ensure quantitative accuracy across each image and between successive images.

Spurious noise filter

An optional real time filter that identifies and compensates for 'spurious' high noise pixels that are greater than 5 electrons (< 1% of all pixels).



Dynamic Baseline Clamp affords superior background image quality (Dark image, Rolling Shutter, 10 ms exposure)

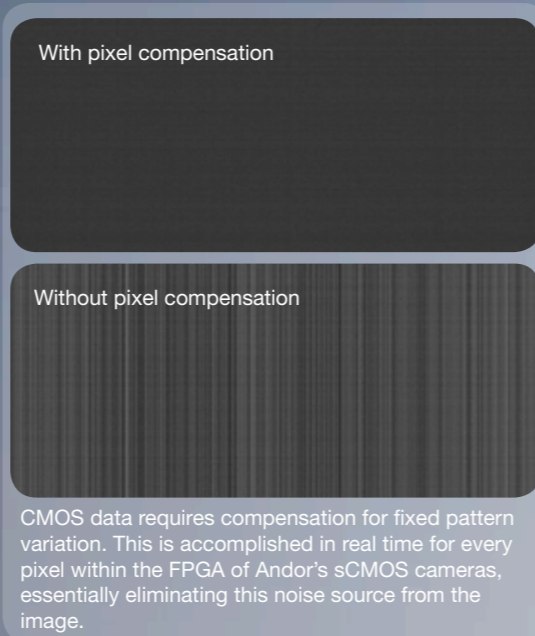

CMOS data requires compensation for fixed pattern variation. This is accomplished in real time for every pixel within the FPGA of Andor's sCMOS cameras, essentially eliminating this noise source from the image.

6.5 μm pixel size combined with 30,000 electron well depth

The 6.5 μm pixel present in Neo and Zyla has been specifically designed to offer an optimal balance of optical resolution, photon collection area and well depth. This pixel size has been determined to provide ideal over-sampling of the diffraction limit in typical cell microscopy with x 60 and x 100 objectives.

- Ideal balance of resolution, photon collection and well depth
- Superb 30,000 electron well depth
- No pixel binning required = no doubling of read noise
- No demagnification optics = no wasteful photon loss

Large Field of View

The 5.5 megapixel sensor present in Neo and Zyla offers an extended field of view with 21.8 mm diagonal, markedly exceeding the FOV available from alternative scientific Interline, EMCCD and CMOS detectors.

Flexibility is key however, and if a large FOV is not required for a particular application, Neo and Zyla offer a range of pre-selected ROI sizes at the click of a button, as well as user defined ROI capability.

- 21.8 mm diagonal
- Closely matched to modern microscopes
- Pre-selected ROIs to quickly opt for smaller FOV if required
- x 3.5 larger than popular 512 x 512 EMCCD sensor
- x 3.9 larger than popular 1.4 MP Interline CCD sensor
- Combine large FOV with dual wavelength image splitter (OptoSplit)

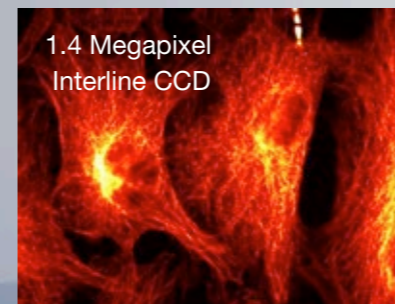
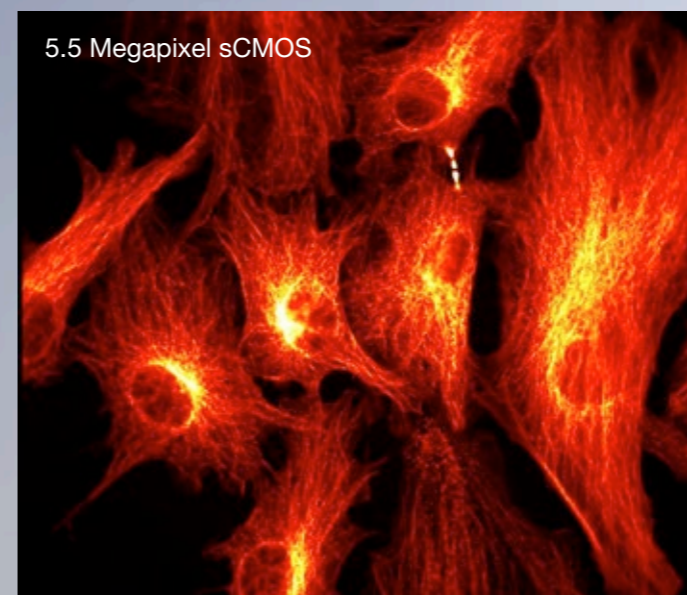

Field of View Comparison

Andor sCMOS vs popular 1.4 megapixel Interline CCD

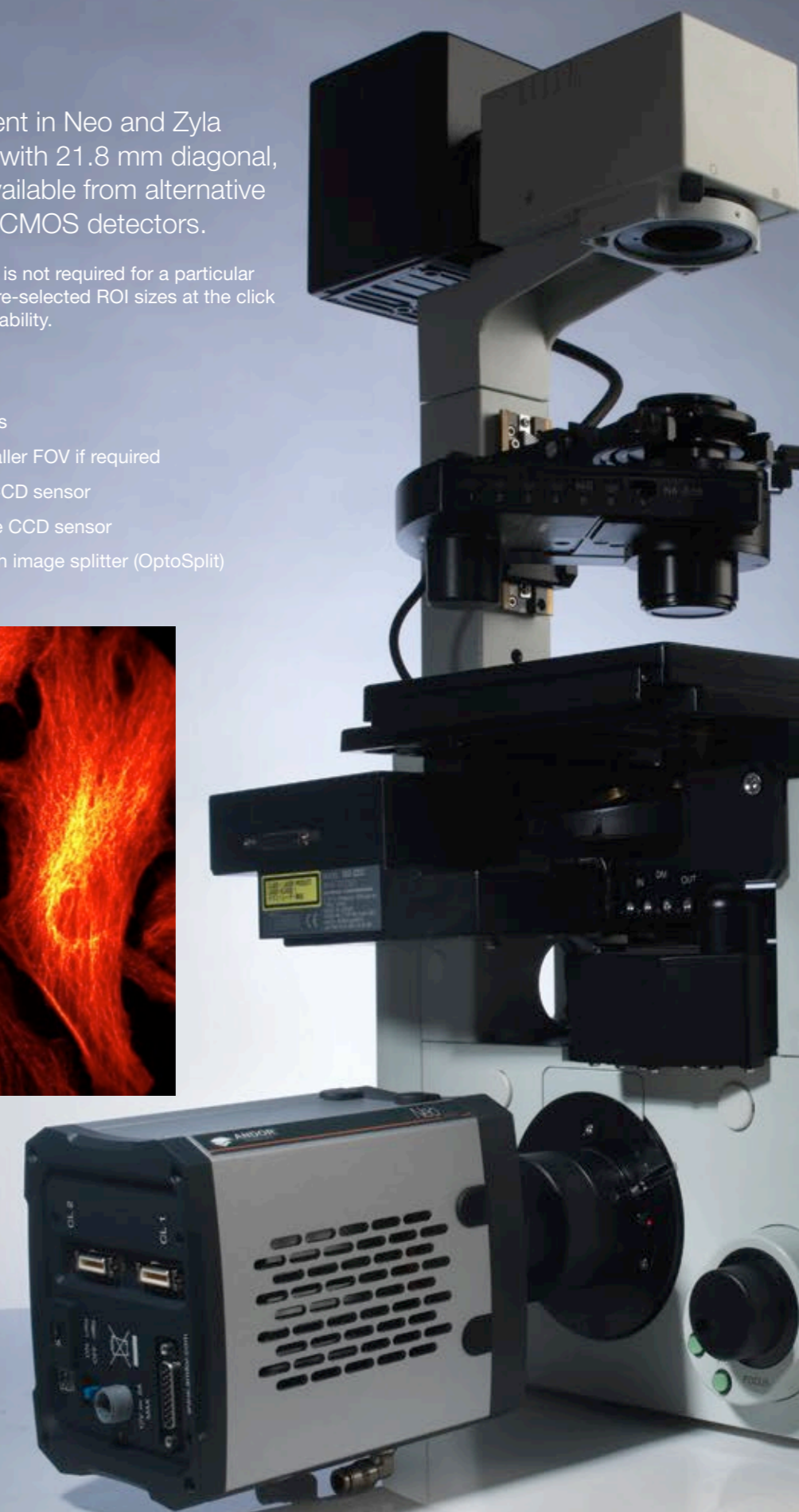

Performance and Innovations

Rolling and Global (Snapshot) Shutter modes

Neo and Zyla are distinct in offering both Rolling Shutter and Snapshot exposure modes from the same sensor, such that the most appropriate mode can be selected dependent on application requirements.

Global Shutter, which can also be thought of as a 'Snapshot' exposure mode, means that all pixels of the array are exposed simultaneously, providing a 'freeze frame' capability that emulates an interline CCD. Benefits include absolute time correlation between all regions of the image, no spatial distortion possibility and ease of synchronization.

Global Shutter exposure and readout (single scan)



Exposure start Exposure Exposure End

Rolling Shutter is a more 'transient' exposure mechanism, different lines of the array exposed at different times as the read out 'waves' sweep through the sensor. The fastest frame rates are available from this mode.

Rolling Shutter exposure and readout (single scan)



Exposure start Exposure Readout

Comprehensive trigger functionality

Neo and Zyla offer a selection of advanced trigger modes, designed to provide tight synchronization of the camera within a variety of experimental set-ups. Triggering is compatible with both Rolling and Global Shutter modes.

- External TTL, Software and Internal trigger
- Rolling and Global Shutter trigger modes
- 'Time Lapse' and 'Continuous' (overlapped) kinetic series
- Fast exposure switching (iCam)



See page 22 for 'Rolling and Global (Snapshot) Exposure Capability' technical note

Trigger Mode	Description	Trigger sources
Time Lapse	Each exposure started by a trigger event (e.g. TTL rising edge). Exposure duration is internally defined.	Internal, External Software
Continuous	Exposures run back to back with no time delay between them. Exposure time defined by time between consecutive trigger events.	Internal, External
External Exposure	Exposure time defined by TTL width (sometimes known as 'bulb mode').	External
External Start	TTL rising edge triggers start of internally defined kinetic series.	External trigger, followed by internal timer

Available Neo and Zyla trigger modes, applicable to both Rolling and Global Shutter.

sCMOS Software Solutions

Andor Solis

Solis is a ready to run Windows package with rich functionality for data acquisition and image analysis/processing.

Andor Basic provides macro language control of data acquisition, processing, display and export.

Andor SDK

A software development kit that allows you to control the Andor range of cameras from your own application. Available as 32 and 64-bit libraries for Windows (XP, Vista and 7) and Linux. Compatible with C/C++, LabView and Matlab.

Andor iQ

A comprehensive multi-dimensional imaging software package. Offers tight synchronization of EMCCD with a comprehensive range of microscopy hardware, along with comprehensive rendering and analysis functionality. Modular architecture for best price/performance package on the market.

Bitplane Imaris

Imaris delivers all the necessary functionality for visualization, segmentation and interpretation of multidimensional datasets.

By combining speed, precision and intuitive ease-of-use, Imaris provides a complete set of features for handling multi-channel image sets of any size up to 50 gigabytes.

Third Party Software Compatibility

The range of third party software drivers for Andor's sCMOS camera platforms are expanding steadily. Please enquire for further details.

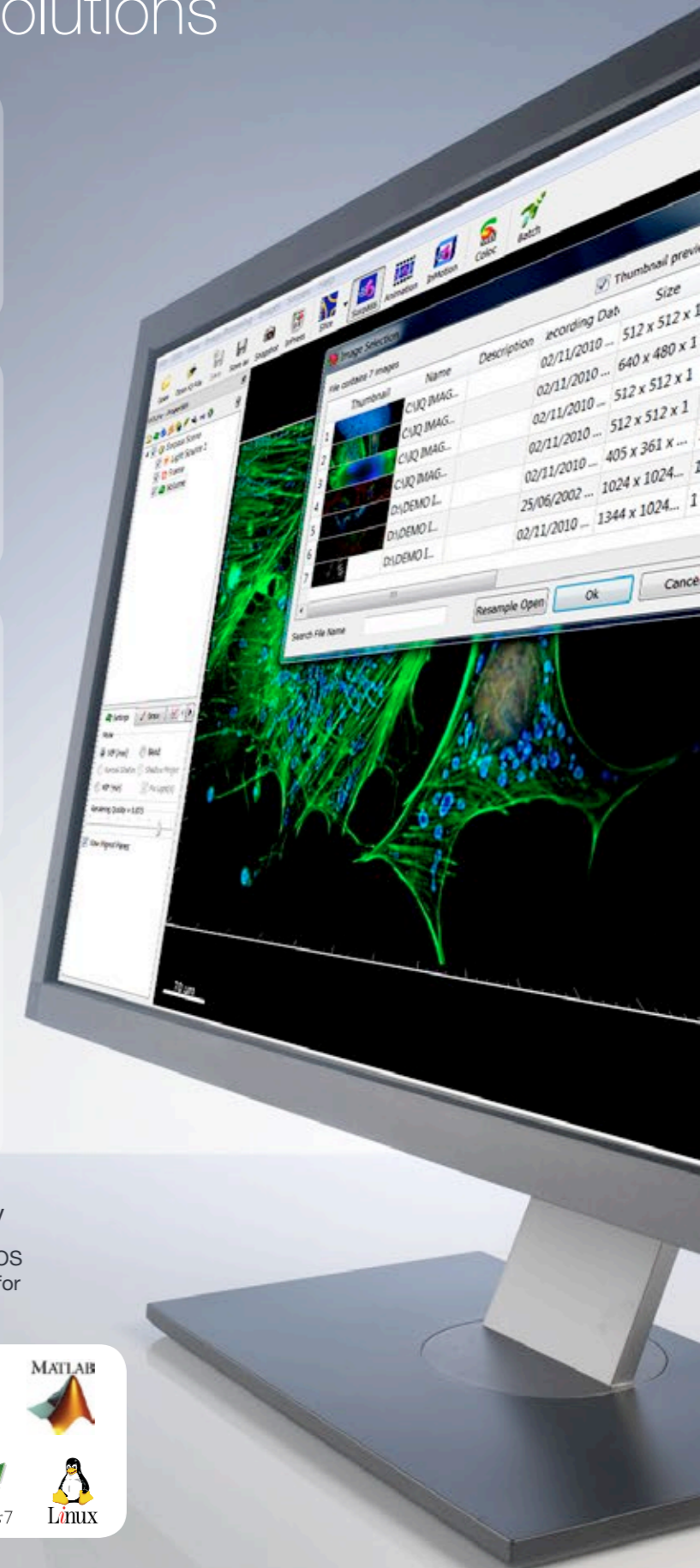

The Andor Imaging Range

Have you found what you are looking for? As an alternative to the sCMOS series, Andor offers an extensive portfolio of high performance low light imaging camera technologies.

Neo - sCMOS, vacuum cooled, lowest noise

- 1 electron read noise @ 30 fps
- 5.5 Megapixel / 6.5 μm
- -40°C vacuum cooling
- 30 fps sustained; 100 fps burst
- 4 GB on head memory
- 16-bit data range
- Fan off vibration free mode

Zyla - sCMOS, fast, sensitive, compact and light

- 1.2 electron read noise @ 30 fps
- 5.5 Megapixel / 6.5 μm
- 0°C cooling at +35°C ambient
- 100 fps sustained (10-tap Camera Link)
- Cost effective 30 fps option (3-tap Camera Link)
- 16-bit data range

iXon - high performance EMCCD platform

- Single photon sensitive and back-illuminated
- Industry fastest frame rates
- -100°C cooling
- Flexible yet intuitive
- Quantify in electrons or photons

iKon - deep cooled, low noise CCD

- -100°C cooling
- Back-illuminated > 90% QE
- 1 megapixel to 4 megapixel
- Enhanced NIR versions
- 'PV Inspector' model – optimized for EL / PL in-line inspection
- USB 2.0 true plug and play

Clara - high-performance interline CCD platform

- Industry lowest interline read noise (2.4 e⁻)
- -55°C fan cooled; -40°C vibration free mode
- 1.4 megapixel
- USB 2.0 true plug and play

Luca^{EM} - price / performance EMCCD platform

- Single photon sensitive
- Compact
- Luca R – megapixel format; 12.4 fps
- USB 2.0 true plug and play

“

We tested the Andor sCMOS camera in conjunction with a popular cooled CCD camera, and compared with results from a similar test of a competitor's scientific CMOS camera. Andor's camera showed lowest dark noise, biggest field of view with very good sampling resolution (number of pixels), fastest frame rate, compatible signal to noise ratio and potentially largest dynamic range of detection. It is the most suitable camera on the market for our project.



Dr. Yan Gu
Confocal Imaging and Analysis Lab
National Institute for Medical Research

”



Technical Notes

New technology and innovation heralds a lot of new questions!

The following section is dedicated to providing a greater depth of understanding of the performance and innovations associated with the Andor scientific CMOS camera platform. Deeper insight is provided into areas such as the unique dual amplifier architecture (for extended dynamic range), sCMOS read noise distribution, dark noise effects, vacuum sensor protection and 'Rolling' vs. 'Global' Shutter readout modes.

We also present a comprehensive overview of how new sCMOS technology compares to existing 'gold standard' scientific imaging cameras such as Interline CCD and EMCCD technology.

- Rolling and Global (Snapshot) Exposure Capability
- Dual Amplifier Dynamic Range
- The Importance of TE Cooling to sCMOS Technology
- Understanding Read Noise in sCMOS
- Comparing sCMOS With Other Scientific Detectors
- Andor sCMOS PC Recommendations and Data Flow Considerations

TIRF Microscopy of mouse cells showing the location of two distinct proteins which have been fluorescently labelled with green fluorescent protein (GFP) and red fluorescent protein (RFP). The green spots represent vesicles in the outer membrane of the cells and the red spots represent vesicles inside the cell.

Image courtesy of Dr. Roberto Zoncu, Whitehead Institute for Biomedical Research, MIT.

Technical Note

The Importance of TE Cooling to sCMOS Technology

Since the read noise of scientific CMOS technology is extremely low, very careful attention must be given to the contribution of thermal noise, which if left unchecked carries potential to sacrifice the low noise floor advantage of the technology. Deep thermoelectric cooling provides the key to maintaining a minimized detection limit through suppression of darkcurrent, whilst simultaneously reducing the occurrence of hot pixel blemishes.

Part 1 - Effect on Noise Floor

The ultra-low value of 1 electron rms read noise available from sCMOS cameras is entirely unprecedented, and dramatically outperforms even the best CCD to date. Read noise is an important contributor to the noise floor detection limit of a camera, but the noise associated with thermal signal, darkcurrent, should never be overlooked. In CMOS cameras especially, even modest exposure times can result in a significant increase in dark noise. Furthermore, since scientific CMOS cameras have a much lower read noise budget, than the percentage increase in dark current can be proportionally large.

Andor's sCMOS cameras have each been designed to implement effective sensor cooling. In fact, the Andor Neo sCMOS platform is unique in the market in that it is the only commercially available CMOS camera with vacuum technology, offering the level of deep thermoelectric cooling necessary to absolutely minimize the detrimental influence of dark noise. Figure 1 shows theoretical plots of noise floor versus exposure time, at three different cooling temperatures, +5°C, 0°C and -30°C. The parameters used in determining the overall noise floor are based on a typical read noise "baseline" of ~ 1 electrons, combined with the measured typical darkcurrent of the CIS 2011 sCMOS sensor at each of the temperatures, +5°C and -30°C from the Andor Zyla and Neo sCMOS cameras respectively. The darkcurrent value used for +5°C has been taken from the spec sheet of a competitive camera using the same sensor. Combined noise is calculated in quadrature, i.e. using the "square root of the sum of the squares method".

Even within the exposure range up to 2 sec, the low noise floor can be notably unaffected by almost 20% as the higher temperature of +5°C. Cooling to -30°C maintains the 1 electron noise floor over the short exposure range. At an exposure time of 10 sec, the noise floor associated with +5°C is significantly compromised to a value greater than 6 electrons, i.e. 10 times the read noise, whereas the noise floor is maintained in values less than 1.5 electrons with deeper cooling.

For very low light measurements, such as in single-molecule detection, it can sometimes be desirable to apply exposure times up to or greater than 10 minutes. At 100 sec, the noise floor associated with +5°C or greater than 10 electrons would occur, whereas the cooling temperature at -30°C would ensure the noise floor being held at a noise budget 2.4 electrons over this extensive exposure period.

Figure 2 shows dark images of 2 second exposure, taken with the sCMOS versus that of a competitive CMOS (same sensor type @ +5°C). The same relative intensity scaling (in terms of electron detection) is used to display each. The detrimental effect of elevated darkcurrent is evident, manifest also in the comparative single row intensity profiles derived from each image.

Part 2 - Effect on Hot Pixel Blemishes

CMOS sensors are particularly susceptible to hot pixel blemishes. These are spurious noise pixels that have significantly higher darkcurrent than the average. Through long TE cooling of the sensor, it is possible to dramatically minimize the occurrence of such hot pixels within the sensor, meaning that these pixels can still be used for scientific applications. Table 1 shows the typical number of pixels with higher than average darkcurrent can be identified in a typical 10 second exposure. The number of pixels with higher than average darkcurrent can be identified in a typical 10 second exposure can be identified in a typical 10 second exposure can be identified in a typical 10 second exposure.

Temperature	Hot Pixels
+5°C	28,500
0°C	1,800
-30°C	1,800

Table 1 - Typical number of hot pixels in a 10 second exposure of a CMOS sensor cooled to +5°C, 0°C and -30°C. The number of hot pixels is significantly reduced at -30°C compared to +5°C and 0°C.

Figure 3 shows a 10 second exposure of the same sensor type as in Figure 2, but with only 1 sec exposure. The sensor is cooled to +5°C. It is clear that cooling to -30°C and beyond is highly effective in reducing the occurrence of hot pixel blemishes. The effect of cooling is also evident in the intensity profiles shown in Figure 4. The profiles show that the noise floor is significantly lower at -30°C compared to +5°C. The profiles also show that the noise floor is significantly lower at -30°C compared to +5°C.

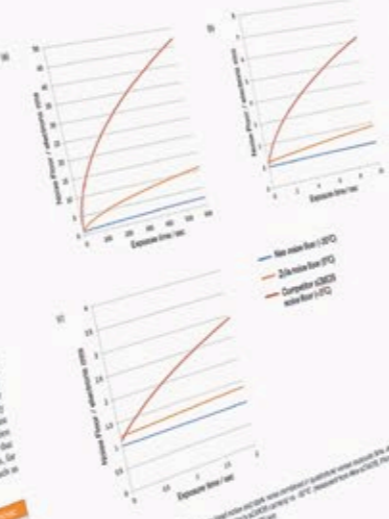

Figure 1 - Theoretical plots of noise floor versus exposure time at three different cooling temperatures: +5°C, 0°C, and -30°C.

Figure 2 - Dark images of 2 second exposure, taken with the sCMOS versus that of a competitive CMOS (same sensor type @ +5°C).

Figure 3 - 10 second exposure of the same sensor type as in Figure 2, but with only 1 sec exposure. The sensor is cooled to +5°C.

Figure 4 - Intensity profiles derived from the images shown in Figure 2 and Figure 3.

Technical Note

Rolling and Global (Snapshot) Exposure Capability

The Andor Neo sCMOS camera is the first scientific CMOS camera to offer both Rolling and Global (Snapshot) exposure capability. This allows users to choose the exposure mode that best suits their application. Rolling exposure is ideal for time-lapse imaging, while Global exposure is ideal for capturing a single snapshot of a scene. The Neo sCMOS camera is designed to provide the flexibility and performance needed for a wide range of scientific imaging applications.

Parameter	Value
Read Noise	1.0 electrons rms
Dark Current	0.1 electrons/sec
Dynamic Range	100,000:1
Frame Rate	100 fps
Resolution	2048 x 2048 pixels
Shutter Type	Global/ Rolling
Temperature Range	+5°C to -30°C

Table 1 - Key performance indicators for the Andor Neo sCMOS camera.

Technical Note

Rolling and Global Shutter

The CIS2051 sCMOS sensor in both Neo and Zyla cameras was designed with a 5T (5 transistor) pixel architecture to offer choice of both Rolling and Global Shutter modes (also called Rolling and Global Exposure modes). This provides superior application and synchronization flexibility and the ability, through global shutter, to closely emulate the familiar ‘Snapshot’ exposure mechanism of interline CCDs.

Rolling and Global Shutter modes describe two distinct sequences through which the image may be read off a sCMOS sensor. In rolling shutter, different lines of the array are exposed at different times as the read out ‘wave’ sweeps through the sensor, whereas in global shutter mode each pixel in the sensor begins and ends the exposure simultaneously, analogous to the exposure mechanism of an interline CCD. However, absolute lowest noise and fastest non-synchronized frame rates are achieved from rolling shutter mode.

Traditionally, most CMOS sensors offer either one or the other, but CIS2051 offers the choice of both rolling and global from the same sensor. With Neo and Zyla sCMOS cameras, the user benefits from the capability to select (via software selection) either readout mode from the same sensor, such that the most appropriate mode can be chosen dependent on specific application requirements.

Rolling Shutter

Rolling Shutter mode essentially means that adjacent rows of the array are exposed at slightly different times as the readout ‘waves’ sweep through each half of the sensor. That is to say, each row will start and end its exposure slightly offset in time from its neighbor. At the maximum readout rate of 560 MHz, this offset between adjacent row exposures is 10 μ s. The rolling shutter readout mechanism is illustrated in Figure 1. From a point of view of readout, the sensor is split in half horizontally, and each column is read in parallel from the center outwards simultaneously, row after row. At the start of an exposure, the wave sweeps through each half of the sensor, switching each row in turn from a ‘keep clean state’, in which all charge is drained from the pixels in the anti-bloom structure, to an ‘exposing state’ in which light induced charge is collected in each pixel. At the end of the exposure, the readout wave again sweeps through the

sensor, transferring the charge from each row into the readout node of each pixel. The important point is that each row will have been subject to exactly the same exposure time, but the row at the top or bottom of each sensor half would have started and ended its exposure 10 ms (1000 rows x 10 μ s/row) after the rows at the center of the sensor.

Rolling Shutter can be operated in a continuous ‘overlap’ mode when capturing a kinetic series of images, whereby after each row has been read out, it immediately enters its next exposure. This ensures a 100% duty cycle, meaning that no time is wasted between exposures and, perhaps more importantly, no photons are wasted. At the maximum frame rate for a given readout speed (e.g. 100 fps at 560 MHz) the sensor is continuously reading out in overlap mode, i.e. as soon as the readout fronts reach the top and bottom of the sensor, they immediately return to the center to readout the next exposure.

A potential downside of rolling shutter is spatial distortion, resulting from the above described exposure mechanism. Distortion would be more apparent in cases where larger objects are moving at a rate that the image readout could not match. However, distortion is less likely when relatively small objects are moving at a rate that is being temporally oversampled by the frame rate.

A further downside is that different regions of the exposed image will not be precisely correlated in time to other regions, which can be essential for some usages. A final, and very important, factor is that synchronizing (e.g. light source activation or peripheral device movement) to rolling shutter readouts can be complex and also can result in slower cycle times and frame rates, relative to those achievable in global shutter.

Global Shutter – ‘interline CCD mode’

Global Shutter mode, which can also be thought of as a ‘Snapshot’ exposure mode, means that all pixels of the array are exposed simultaneously, thus enabling ‘freeze frame’ capture of fast moving or fast changing events and in this respect, global shutter can be thought of as behaving like an interline CCD sensor. Before the exposure begins, all pixels in the array will be held in a ‘keep clean state’, during which charge is drained into the anti-bloom structure of each pixel. At the start of the exposure, each pixel simultaneously begins to collect charge and is allowed to do so for the duration of the exposure time. At the end of exposure, each pixel transfers charge simultaneously to its readout node.

Global shutter can be configured to operate in a continuous ‘overlap’ mode (analogous to interline CCD), whereby an exposure can proceed while the previous exposure is being readout out from the readout nodes of each pixel. In this mode, the sensor has a 100% duty cycle, again resulting in optimal time resolution and photon collection efficiency. During this entire cycle, there is no period of ‘transient’ readout as found in rolling shutter.

Importantly, Global Shutter mode is very simple to synchronize to and often yields faster frame rates than efforts to synchronize with Rolling Shutter with the same exposure time. Global shutter can also be regarded as essential when exact time correlation is required between different regions of the sensor area.

However, the mechanism of global shutter mode demands that a reference readout is performed ‘behind the scenes’, in addition to the actual readout of charge from each pixel. This additional digitized readout is required to eliminate reset noise from the global shutter image. Due to this additional reference readout, global shutter mode carries the trade-off of halving the maximum unsynchronized frame rate that would otherwise have been achieved in rolling shutter mode.

Rolling Shutter exposure sequence (single frame)

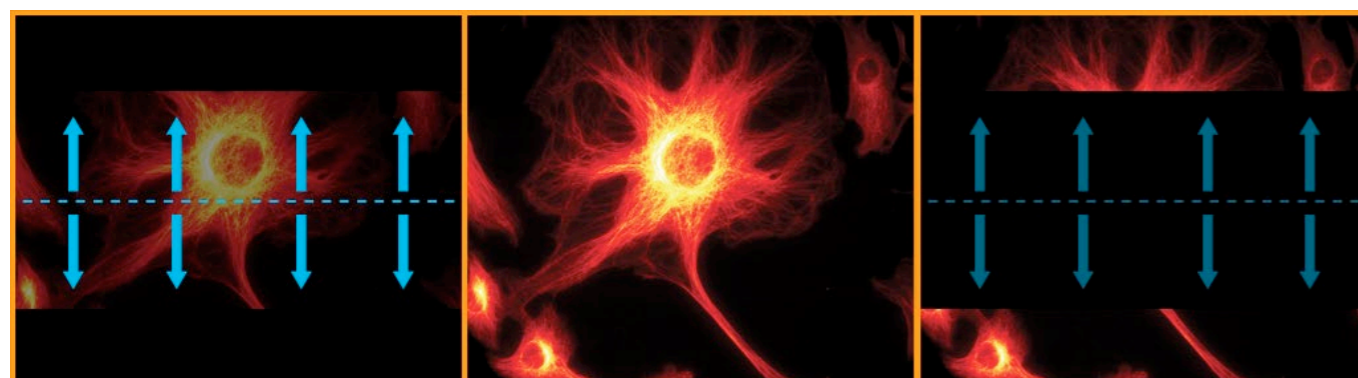

Exposure start Exposure Readout

Global Shutter sequence (single frame)

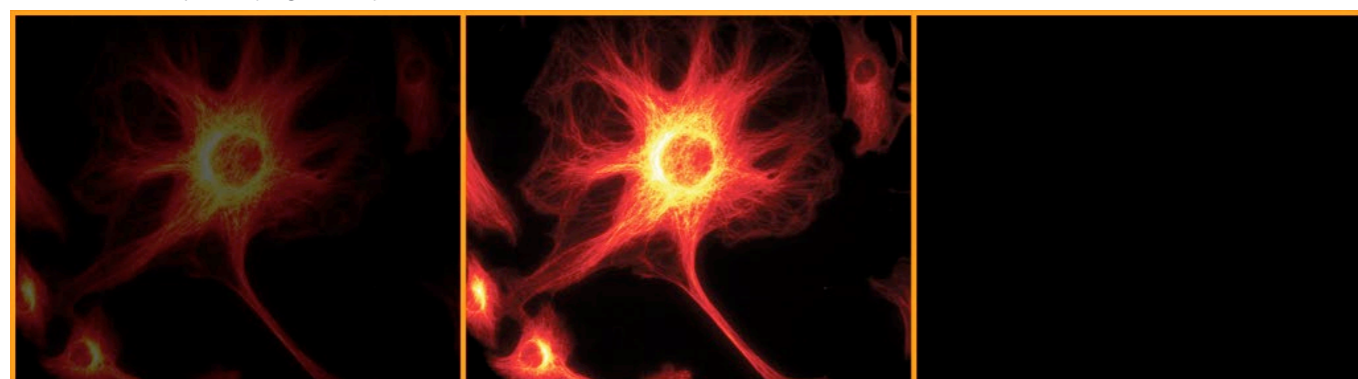

Exposure start Exposure Exposure End

Figure 1 - Simplified illustration showing sequence of events in rolling and global shutter modes. Note that while a single image acquisition is represented, each mode is also compatible with ‘overlap’ readout, whereby the next exposure begins simultaneous with image readout.

	Rolling	Global
Snapshot exposure	No	Yes
Interline CCD similarity	No - very different ‘transient’ exposure sequence	Yes – extremely similar exposure sequence
Temporal correlation between different regions of image area	No - up to 10 ms (@ 560 MHz) difference between centre and top or bottom of image	Yes - all pixels represent exact same time of exposure
Synchronization capability	Complex to synchronize Requires strobe light source Longer cycle times.	Simple to synchronize Any light source Shorter cycle times
Fast double exposure capability	No	Yes
Maximum Frame Rate	Maximum available (non- synchronized)	Maximum frame rates are halved
Read Noise	Lowest possible (1 e ⁻ to 1.3 e ⁻)	Slightly higher (2.3 e ⁻ to 2.6 e ⁻)
Spatial Distortion	Possible if not temporally oversampling object dynamics or shuttering light source	None
Duty Cycle Efficiency	Reduced, e.g. if require to shutter illumination off during ‘transient’ readout phases	Typically much larger since no ‘transient’ readout phase to avoid

Table 1 - Comparing the pros and cons of Rolling vs Global Shutter



Figure 2 – Images of a moving fan, acquired with Neo sCMOS camera with rolling and global shutter exposure modes, same exposure time. The spatial distortion associated with the ‘rolling shutter effect’ is apparent in the left image. Global shutter is a ‘snapshot’ acquisition mode and avoids spatial distortion.

Rolling or Global?

Whether rolling shutter or global shutter is right for you will depend very much on the experiment. Global Shutter has a ‘non-transient’ exposure mechanism that is entirely analogous to that of interline CCDs, and for many will provide the reassurance of ‘freeze frame’ capturing of moving objects or transient events during a kinetic acquisition series with zero spatial distortion, as well as offering simpler and faster synchronization performance. For particular applications, for example where it is required that different regions of the image maintain temporal correlation or where it is required to accurately synchronize to relatively short lived events, global shutter will be viewed as a necessity.

Figure 2 shows images of a moving fan, imaged with both rolling and global shutter exposure modes of the Neo sCMOS camera, identical exposure time. Significant spatial distortion (beyond motion blur) of the fan blades is apparent in the image captured with rolling shutter. The reason for this is that the blades are moving fast relative to the time taken for the ‘transient’ exposure activation /readout fronts of rolling shutter to transverse the blade width. This spatial distortion is often referred to as the ‘rolling shutter effect’.

However, Rolling Shutter mode, with the enhanced non-synchronized maximum frame rate possibility and lower read noise, is still likely to suit many scientific applications, e.g. where one simply needs to track relatively small objects in 2D as a function of time. As long as the frame rate is such that the camera is temporally oversampling object dynamics within the image area, negligible spatial distortion will be observed in rolling shutter mode. Such oversampling is good imaging practice, since it is generally undesirable to have an object travel a significant distance during a single exposure. However, it must always be born in mind that, even if distortion is not manifest, an object at the top of bottom of the image will be captured up to 10 ms apart from an object at the center of the image: if this is a factor for your experiment, then rolling shutter should not be used.

Short charge transfer time between 2 consecutive exposures with Global Shutter

The global shutter mode of Neo can be used to effect electronic gating, similar to that possible with interline CCDs. Before the exposure, all pixels in the array will be held in a ‘keep clean state’, during which charge is drained into the anti-bloom structure of each pixel, thus acting as an ‘electronic shutter’. The exposure ‘switch on’ is electronic and extremely fast (sub- μ s). At the end of exposure, each pixel transfers charge simultaneously to its readout node, again acting as an electronic shutter close mechanism. The transfer time specification for this step is only 2 μ s and has been optical measured to be less than 1 μ s.

The short transfer time between 2 consecutive images in global shutter mode lends the Neo to fast ‘double exposure’ applications, such as Particle Imaging Velocimetry (PIV).

Synchronizing to Rolling and Global shutter

Flexibility to offer both rolling shutter and true global shutter can be considered highly advantageous. Rolling shutter delivers absolute lowest read noise and is best used for very fast streaming of data (> 50 fps full frame) without synchronization to light source or peripheral device. However, it carries risk of spatial distortion, especially when imaging relatively large, fast moving objects. There is no risk of spatial distortion when using true global shutter. To avoid spatial distortion in rolling shutter a simulated global exposure synchronization approach must be used, which requires a pulsed light source and also significantly reduces the duty cycle of photon collection (i.e. reduces photons collected per cycle). By contrast, a 100% duty cycle can be maintained in global shutter.

When synchronizing to fast switching peripheral devices, true Global Shutter mode is relatively simple and can result in faster frame rates. While the read noise in global shutter mode ($\sim 2.5 e^-$) is approximately double that of rolling shutter ($\sim 1.2 e^-$), this can often be offset against

the higher duty cycles (therefore increased photon collection per cycle) and higher synchronized frame rates possible in true global shutter mode.

See separate tech note entitled – ‘Synchronizing to sCMOS cameras – Importance of both Rolling and true Global Exposure’

‘Gen I’ vs ‘Gen II’ sCMOS?

It has been noted with interest that another prominent player in the sCMOS field has opted to apply the term ‘Gen II’ to a 4T (4 transistor) variant of the low noise pixel architecture used in Zyla and Neo cameras. While a 4T design can be considered beneficial in affording a slightly improved Quantum Efficiency response, it does so at the expense of global shutter capability, thus limiting application flexibility and synchronization performance.

In the author’s opinion, it is a considerable stretch to apply an aggressive ‘Gen II’ marketing label to such a sensor variant, when both 4T (rolling shutter) and 5T (global shutter) CMOS concepts have been around for some time and are extremely well documented. In fact, it is the architecture of the CIS2051 sCMOS sensor that, if anything, can be considered more innovative, in that it has been uniquely designed to offer global shutter whilst maintaining rolling shutter capability. When at the design stages, Andor and partners had a choice of 4T rolling shutter or the design we opted for – the decision was taken based on solid application reasoning.

Technical Note

Dual Amplifier Dynamic Range

The Dual Amplifier architecture of sCMOS sensor CIS 2051 in Neo and Zyla uniquely circumvents the need to choose between low noise or high capacity, in that signal can be sampled simultaneously by both high gain and low gain amplifiers respectively. As such, the lowest noise of the sensor can be harnessed alongside the maximum well depth, affording the widest possible dynamic range.

Traditionally, scientific sensors including CCD, EMCCD, ICCD and CMOS, demand that the user must select 'upfront' between high or low amplifier gain (i.e. sensitivity) settings, depending on whether they want to optimize for low noise or maximum well depth. Since the true dynamic range of a sensor is determined by the ratio of well depth divided by the noise floor detection limit, then choosing either high or low gain settings will restrict dynamic range by limiting the effective well depth or noise floor, respectively.

For example, consider a large pixel CCD, with 16-bit Analogue to Digital Converter (ADC), offering a full well depth of 150,000 e⁻ and lowest read noise floor of 3 e⁻. The gain sensitivity required to give lowest noise is 1 e⁻/ADU (or 'count') and the gain sensitivity required to harness the full well depth is 2.3 e⁻/ADU, but with a higher read noise of 5e⁻. Therefore, it does not automatically follow that the available dynamic range of this sensor is given by 150,000/3 = 50,000:1. This is because the high sensitivity gain of 1e/ADU that is used to reach 3 e⁻ noise means that the 16-bit ADC will top out at 65,536 e⁻, well short of the 150,000 e⁻ available from the pixel. Therefore, the actual dynamic range available in 'low noise mode' is 65,536/3 = 21,843:1. Conversely, the lower sensitivity gain setting means that the ADC will top out at ~ 150,000 e⁻, but the higher read noise of 5 e⁻ will still limit the dynamic range to 150,000/5 = 30,000:1 in this 'high well depth mode'.

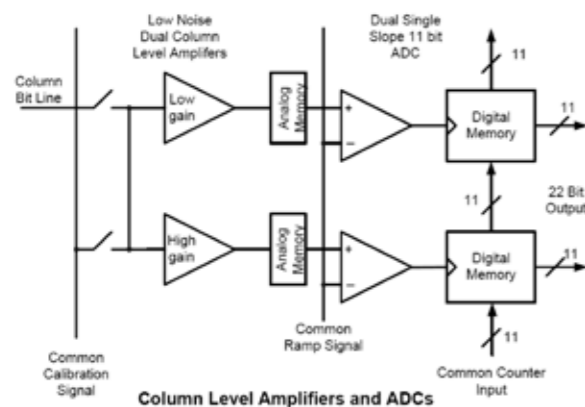

Figure 1 - Schematic layout of sCMOS Columns Level Amplifiers and Analogue to Digital Converters (ADCs)

sCMOS sensor CIS 2051 offers a unique dual amplifier architecture, meaning that signal from each pixel can be sampled simultaneously by both high and low gain amplifiers. The sensor also features a split readout scheme in which the top and bottom halves of the sensor are read out independently. Each column within each half of the sensor is equipped with dual column level amplifiers and dual analog-to-digital converters, represented as a block diagram in Figure 1. The dual column level amplifier/ADC pairs have independent gain settings, and the final image is reconstructed by combining pixel readings from both the high gain and low gain readout channels to achieve a wide intra-scene dynamic range, uniquely so considering the relatively small 6.5 μm pixel pitch.

The method of combining signal from two 11-bit ADCs can be divided into four basic steps:

- 1) At the end of the analogue chain the "Signal" voltage is applied to two independent amplifiers: the high gain amplifier and the low gain amplifier. This results in two separate digital data streams from the sensor.
- 2) In the camera, the FPGA selects which data stream to use on a pixel per pixel, frame by frame basis using a threshold method.
- 3) The data is then corrected for DC offset and gain. Again, this is done on a pixel by pixel basis using the correction data associated with the data stream. The gain corrects for pixel to pixel relative QE, pixel node amplifier and the high and low amplifier relative gains.
- 4) The pixels are then combined into a single 16-bit image for transfer to the PC.

NOTE: Due to the splicing together of the low and high gains, the transition region between them is not seamless but has been optimized as far as possible.

Following simplification of gain modes and readout speeds from Jan 2012, there are now two available individual 11-bit gain settings and one dual amplifier 16-bit setting per shutter mode for 100 MHz and 280 MHz Readout rates, as shown in Table 2. The user maintains the choice of opting to stay with 11-bit single gain channel data if dynamic range is not critical, resulting in smaller file sizes. This in turn offers faster frame rates when continuously spooling through the Camera Link interface and writing to hard disk.

Amplifier Gain	Electrons/count	Noise	Signal to Noise Ratio	Effective Well depth (limited by ADC)
High	Fewer	Lower	Higher	Lower
Low	More	Higher	Lower	Higher

Table 1 - The 'traditional' limiting choice: the mutually exclusive effect of high vs low gain amplifier choice on noise floor and effective well depth.

Amplifier Gain (Previous Andor SDK description)	Amplifier Gain (Current Andor SDK / Solis description)	Mode	Sensitivity e ⁻ /ADU (typical)	Data Range	Effective pixel saturation limit / e ⁻	Spooling file size (5.5 MPixel)
Gain 1 (11 bit)	11 bit (high well capacity)	GS/RS	22	11-bit	30,000	8.5 Mb
Gain 3 (11 bit)	11 bit (low noise)	GS	1.8	11-bit	3,690	8.5 Mb
Gain 4 (11 bit)	11 bit (low noise)	RS	0.6	11-bit	1,230	8.5 Mb
Not previously supported	16 bit (low noise and high well capacity)	GS	1.8	16-bit	30,000	11.3 Mb
Gain 1 Gain 4 (16 bit)	16 bit (low noise and high well capacity)	RS	0.6	16-bit	30,000	11.3Mb

Table 2 - Typical performance of supported gain settings of sCMOS CIS 2051 sensor (Jan 2012 onwards)

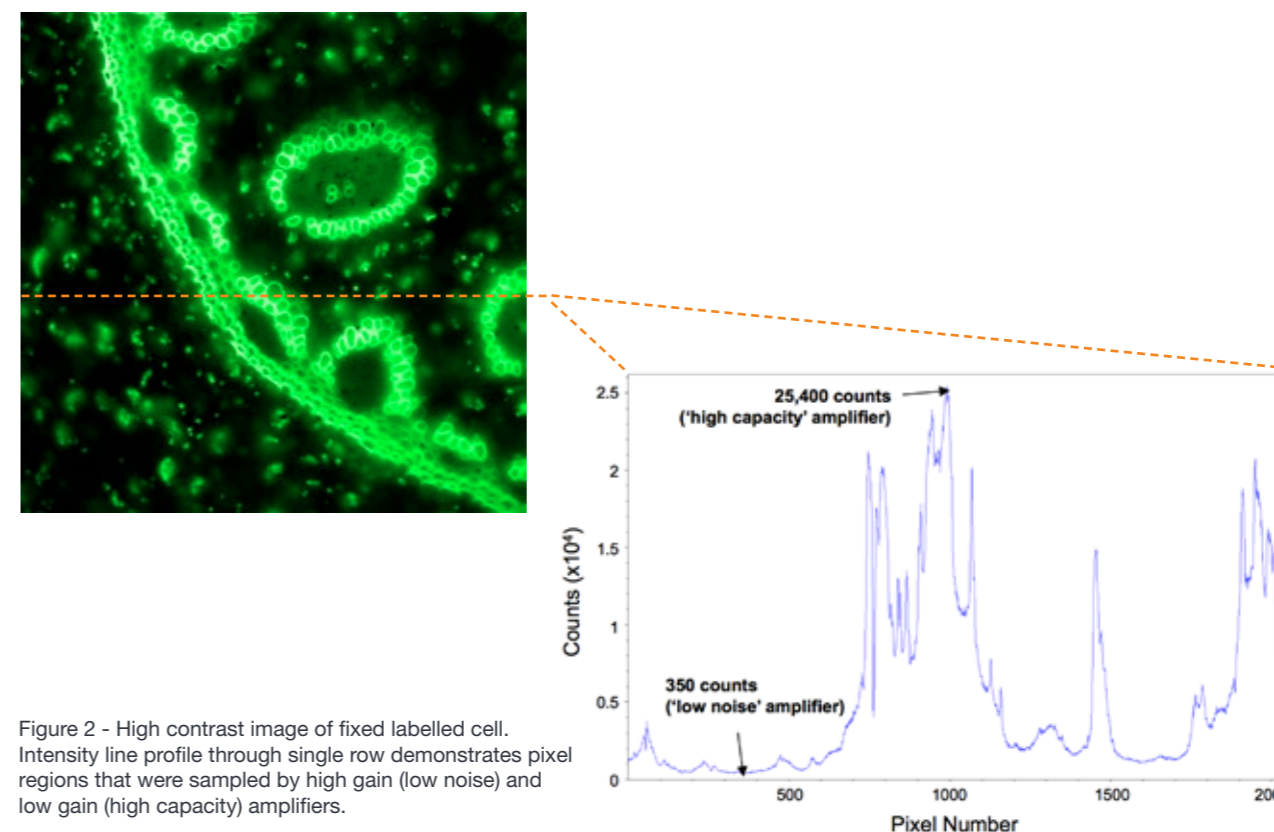

Figure 2 - High contrast image of fixed labelled cell. Intensity line profile through single row demonstrates pixel regions that were sampled by high gain (low noise) and low gain (high capacity) amplifiers.

Technical Note

The Importance of TE Cooling to sCMOS Technology

Since the read noise of scientific CMOS technology is extremely low, very careful attention must be given to the contribution of thermal noise, which if left unchecked carries potential to sacrifice the low noise floor advantage of the technology. Deep thermoelectric cooling provides the key to maintaining a minimized detection limit through suppression of darkcurrent, whilst simultaneously reducing the occurrence of hot pixel blemishes.

Part 1 - Effect on Noise Floor

The ultra-low value of 1 electron rms read noise available from sCMOS cameras is entirely unprecedented, and dramatically outperforms even the best CCD to date. Read noise is an important contributor to the noise floor detection limit of a camera, but the noise associated with thermal signal, darkcurrent, should never be overlooked. In CMOS cameras especially, even modest exposure times can result in a significant increase in dark noise. Furthermore, since scientific CMOS cameras have a much lower read noise baseline, then the percentage increase in dark current can be proportionally larger.

Andor's sCMOS cameras have each been designed to implement effective sensor cooling. In fact, the Andor Neo sCMOS platform is unique in the market in that it is the only commercially available CMOS camera with vacuum technology, offering the level of deep thermoelectric cooling necessary to absolutely minimize the detrimental influence of dark noise. Figure 1 shows theoretical plots of noise floor versus exposure time, at three different cooling temperatures, +5°C, 0°C and -30°C. The parameters used in determining the overall noise floor are based on a typical read noise 'baseline' of ~ 1 electrons, combined with the measured typical darkcurrent of the CIS 2051 sCMOS sensor at each of the temperatures, the values for 0°C and -30°C from the Andor Zyla and Neo sCMOS cameras respectively. The darkcurrent value used for +5 C has been taken from the spec sheet of a competitive camera using the same sensor. Combined noise is calculated in quadrature, i.e. using the 'square root of the sum of the squares method'.

Even within the exposure range up to 2 sec, the low noise floor can be notably sacrificed by almost 200% at the higher temperature of +5°C. Cooling to -30°C maintains the 1 electron noise floor over this short exposure range. At an exposure time of 10 sec, the noise floor associated with +5°C is significantly compromised to a value greater than 6 electrons, i.e. x6 greater than the read noise, whereas the noise is maintained to values less than 1.5 electrons with deeper cooling.

For very low light measurements, such as in chemiluminescence detection, it can sometimes be desirable to apply exposure times up to or greater than 10 minutes. At 600 sec, unless deep cooling is applied, the thermal contribution to the noise floor would become excessively large, shown in graph C as reaching > 45 electrons at +5°C. Holding the cooling temperature at -30°C would result in the noise floor being held at a more modest 2.4 electrons over this extensive exposure period.

Figure 2 shows dark images of 2 second exposure, taken with Neo sCMOS versus that of a competitor's sCMOS (same sensor type) @ + 5°C. The same relative intensity scaling (in terms of absolute electrons) is used to display each. The detrimental effect of elevated bulk darkcurrent is evident, manifest also in the comparative single row intensity profiles derived from each image.

Part 2 - Effect on Hot Pixel Blemishes

CMOS sensors are particularly susceptible to hot pixel blemishes. These are spurious noise pixels that have significantly higher darkcurrent than the average. Through deep TE cooling of the sensor, it is possible to dramatically minimize the occurrence of such hot pixels within the sensor, meaning that these pixels can still be used for useful quantitative imaging. Table 1 shows that the typical number of pixels with higher than average darkcurrent can be dramatically limited in practice through cooling of the sensor, meaning that they are not required to be treated by interpolation filters. Such interpolation over pixel blemishes can be detrimental in some applications that depend on total quantitative integrity over a limited set of pixels, for example in localization based super-resolution microscopy (such as PALM and STORM techniques).

Cooling Temperature	# hot pixels with > 2e-/pix/sec
+5°C	28,500
-30°C	1,800

Table 1 – Typical number of hot pixels (i.e. higher than average darkcurrent pixels) of the 5.5MP 2051 sCMOS sensor that show darkcurrent greater than 2 e-/pix/sec at cooling temperatures of +5°C and -30°C.

Figure 3 (a) shows a 3D intensity plot of the same region of a sCMOS CIS2051 sensor at a number of different cooling temperatures, each recorded with only 1 sec exposure time in rolling shutter mode. It is clear that cooling to -30°C and beyond is highly effective in reducing the occurrence of hot pixel spikes, thus offering both an aesthetically cleaner image and a greater proportion of useable and meaningful pixels. This in turn means that significantly fewer pixels need be treated using a nearest neighbor median replacement algorithm. Even using very short exposure conditions of 30 ms, there are still significant numbers of hot pixels present at higher cooling temperatures, as illustrated in figure 3 (b).

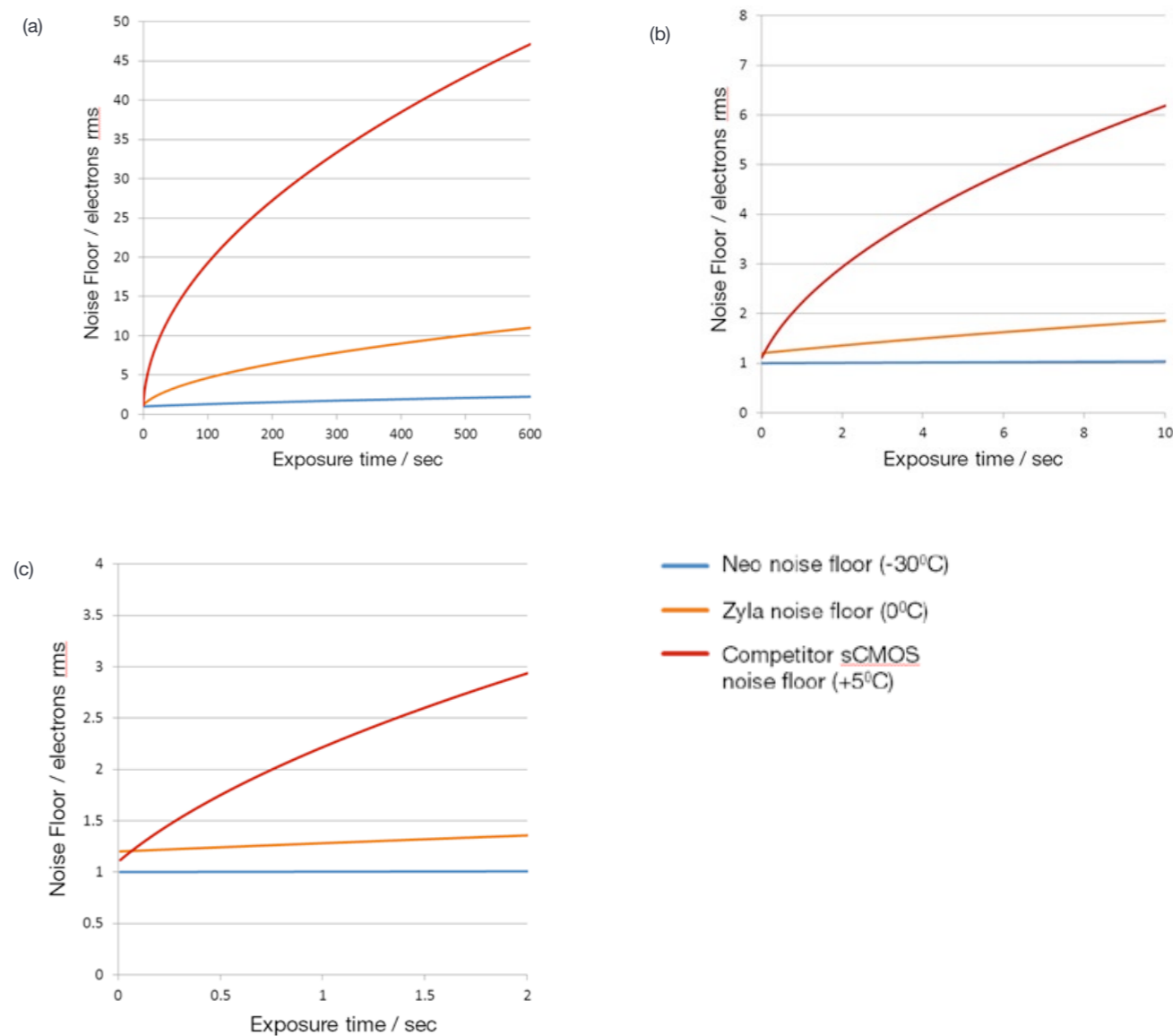

Figure 1 - Plots of sCMOS noise floor (read noise and dark noise combined in quadrature) versus exposure time, at sensor cooling temperatures of +5°C measured from competitor's sCMOS camera vs. 0°C and -30°C (measured from Zyla and Neo sCMOS respectively). Plots are shown over three ranges of exposure time: 0 - 2 sec, 0 - 10 sec and 0 - 600 sec

Part 3 – Minimization of Vibration

Many optical configurations are sensitive to vibrations from the camera fan, such as patch clamp or combined optical/AFM set-ups. The deep cooling advantage of Neo means that the internal fan can be turned off by instead opting to flow water through the conveniently located connections. Andor's Neo offers:

- Two fan speeds
- Ability to turn off fan completely.

'Liquid cooling' through the camera allows minimization of vibration while still stabilizing at -40°C . Alternatively, if complete vibration free operation is required without water cooling, the Neo fan can be turned off for a limited period of time, during which the camera is passively cooled. Table 2 shows typical fan-off durations that apply when the Neo camera is operated in a $+25^{\circ}\text{C}$ ambient environment.

Sensor Readout Speed	Selected Sensor Temperature	Duration Before Fan Is Forced On
560 MHz	0°C	60 minutes
560 MHz	5°C	79 minutes
560 MHz	15°C	93 minutes
560 MHz	-15°C	9 minutes
560 MHz	-30°C	5 minutes
200 MHz	-15°C	18 minutes
200 MHz	-30°C	12 minutes

Table 2 - Examples of what fan-off durations achievable across a range of cooling temperatures and readout speeds when operating Neo sCMOS in an ambient environment of 25°C

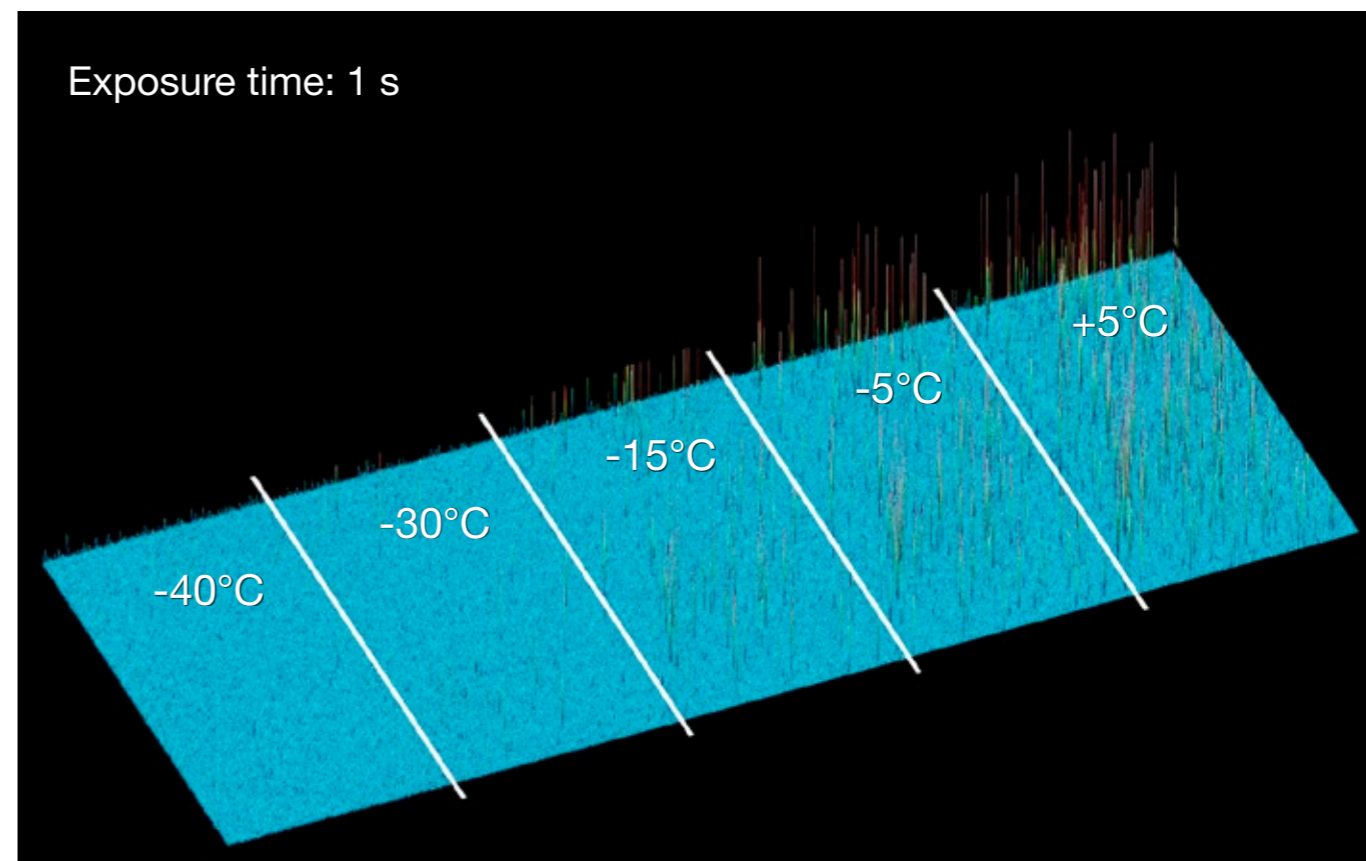

Figure 3 (a) – Blemishes at different temperatures for 1 sec exposure.

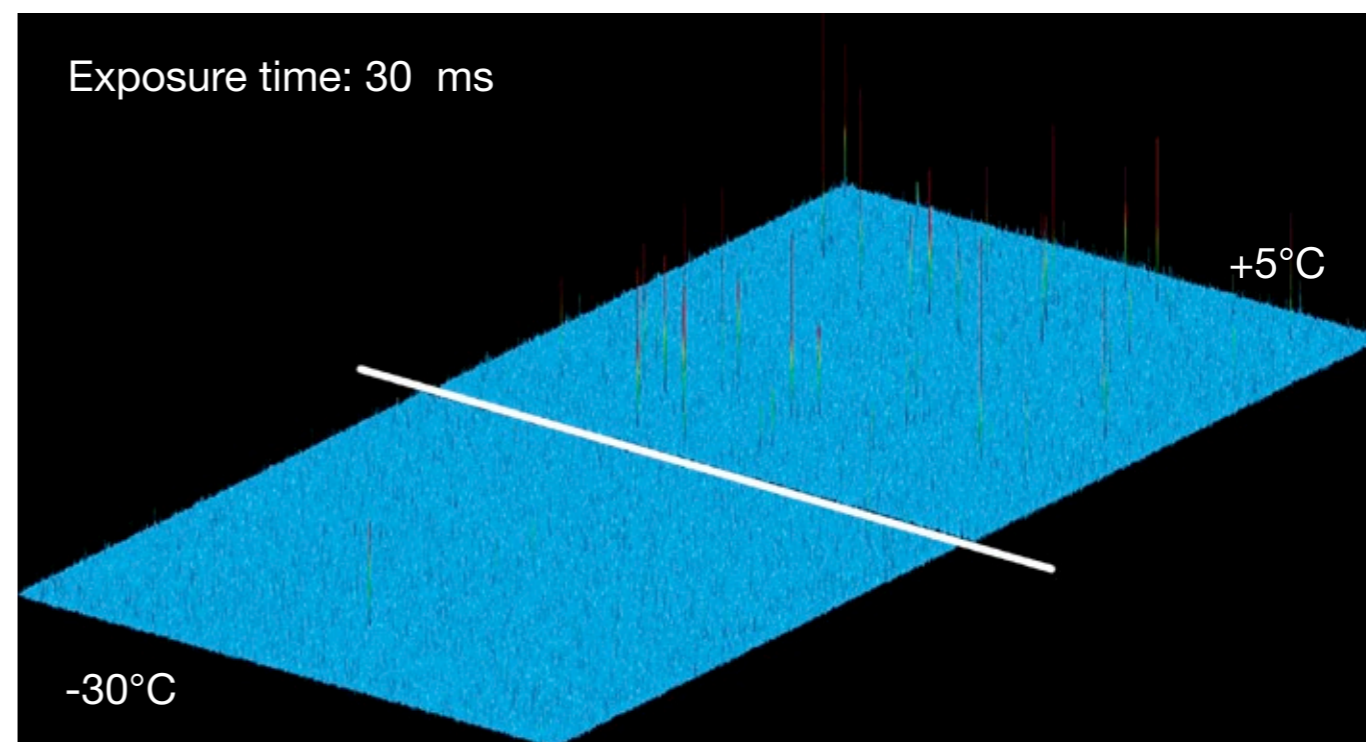

Figure 3 (b) – Blemishes at -30°C vs $+5^{\circ}\text{C}$ for 30 ms exposure

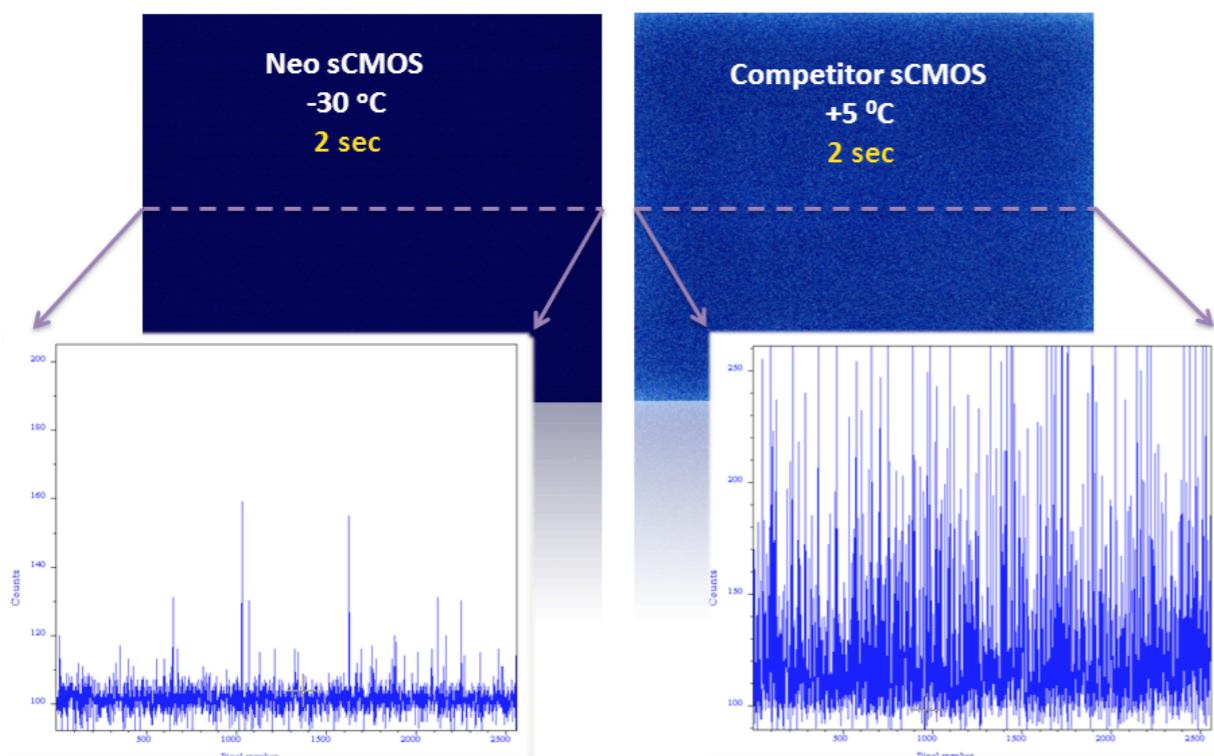

Figure 2 - Thermal noise can sacrifice the sCMOS low detection limit. Low light images recorded with a Neo sCMOS at -30°C versus a competing sCMOS @ $+5^{\circ}\text{C}$. Shown with same relative intensity scaling; 2 sec exposure time; 560MHz readout speed. Comparative line intensity profiles from a single row is also shown for each case.

Technical Note

Comparing sCMOS with Other Scientific Detectors

sCMOS technology is unique in its ability to overcome many of the mutual exclusivities that have marred other scientific detector technologies, resulting in an imaging detector that simultaneously optimizes a range of important performance parameters whilst maintaining Snapshot exposure capability.

Part 1 - Current scientific imagers: Interline CCD and EMCCD

Many scientific imaging applications demand multi-megapixel focal plane sensors that can operate with very high sensitivity and wide dynamic range. Furthermore, it is often desirable that these sensors are capable of delivering rapid frame rates in order to capture dynamic events with high temporal resolution. Often there is a strong element of mutual exclusivity in these demands. For example, it is feasible for CCDs to achieve less than 3 electrons rms readout noise, but due to the serial readout nature of conventional CCDs, this performance comes at the expense of frame rate. This is especially true when the sensor has several megapixels of resolution. Conversely, when CCDs are pushed to faster frame rates, resolution and field of view are sacrificed (i.e. fewer pixels per frame to read out) or read noise and dynamic range suffer.

By way of illustration, consider one of the most popular, high-performance front-illuminated scientific CCD technologies on the market today – the Interline CCD. These devices are capable of reading out at 20 megapixel/s per output port with a respectable read noise of only 5 to 6 electrons rms. At this readout speed a single port 1.4 megapixel sensor can achieve 11 fps. Use of microlenses ensures that most of the incident photons are directed away from the Interline metal shield and onto the active silicon area for each pixel, resulting in peak QE greater than 60%. High performance combined with low cost has made the Interline CCD a very popular choice for applications such as fluorescence cell microscopy, luminescence detection and machine vision. However, even 5 to 6 e⁻ noise is too high for many low light scientific applications. For example, when imaging the dynamics of living cells, there is a need to limit the amount of fluorescence excitation light, such that both cell phototoxicity and photobleaching of the fluorescent dyes is minimized. The use of lower power excitation results in a proportionally lower fluorescent emission signal from the cell. Also dynamic imaging yields shorter exposure times per frame, thus fewer photons per frame. Ultra low light conditions mean that the read noise floor can often become the dominant detection limit, seriously compromising the overall signal-to-noise ratio (SNR) and hence the ability to contrast fine structural

features within the cell. As such, the inability to maintain low noise at faster readout speeds limits the overall flexibility of the Interline CCD camera.

The Electron Multiplying CCD (EMCCD) was introduced into the market by Andor in 2000 and represents a significant leap forward in addressing the mutual exclusivity of speed and noise as discussed above. EMCCD cameras employ an on-chip amplification mechanism called ‘Impact Ionization’ that multiplies the photoelectrons that are generated in the silicon. As such, the signal from a single photon event can be amplified above the read noise floor, even at fast, multi-MHz readout speeds. Importantly, this renders the EMCCD capable of single photon sensitivity at fast frame rates (e.g. 34 fps with a 512 x 512 array). This attribute has rapidly gained recognition for EMCCD technology in demanding low light measurements, such as single molecule detection.

However, despite the sensitivity under extremely low light conditions, there are a few remaining drawbacks of EMCCD technology. The amplification mechanism required to reduce the effective read noise to < 1e⁻, also induces an additional noise source called multiplicative noise. This effectively increases the shot noise of the signal by a factor of 1.41, which is manifested as an increase in the pixel to pixel and frame to frame variability of low light signals. The net effect of multiplicative noise is that the acquired image has a diminished signal-to-noise ratio, to an extent that the QE of the sensor can be thought to have been effectively reduced by a factor of two. For example, a QE-enhanced back-illuminated EMCCD with 90% QE has effectively 45% QE when the effects of multiplicative noise are considered. Dynamic range limitations of EMCCDs must also be considered. It is possible to achieve respectably high dynamic range with a large pixel (13 to 16 μm pixel size) EMCCD, but only at slow readout speeds. As such, higher dynamic range can only be reached at slower frame rates (or with reduced array size) with modest EM gain settings. Application of higher EM gain settings results in the dynamic range being depleted further. Sensor cost of EMCCD technology is an additional consideration, along with the practical restriction on resolution and field of view that accompanies sensor cost. Presently, the largest commercially available EMCCD

Array Size (H x V)	Rolling Shutter mode (fps)	Global (Snapshot) Shutter mode (fps)
2560 x 2160 (full frame)	100	50
2064 x 2048 (4 megapixel)	104	52
1392 x 1040 (1.4 megapixel)	204	100
512 x 512	412	200
128 x 128	1,616	711

Table 1 - Frame rate vs sub-window size; Rolling and Global Shutter readout modes. N.B. Same sub-window frame rates apply when using full horizontal width with the vertical heights indicated (see body text for further detail).

sensor is a back-illuminated 1024 x 1024 pixel device with 13 μm pixel pitch, representing a 13.3 x 13.3 mm sensor area. This already carries a significant cost premium, making further expansion to multi-megapixel devices a costly proposition.

Part 2 - sCMOS: Circumventing the trade-offs

Scientific CMOS (sCMOS) technology is based on a new generation of CMOS design and process technology. This device type carries an advanced set of performance features that renders it entirely suitable to high fidelity, quantitative scientific measurement. sCMOS can be considered unique in its ability to simultaneously deliver on many key performance parameters, overcoming the ‘mutual exclusivity’ that was earlier discussed in relation to current scientific imaging technology standards, and eradicating the performance drawbacks that have traditionally been associated with conventional CMOS imagers.

The 5.5 megapixel sensor offers a large field of view and high resolution, without compromising read noise or frame rate. The read noise in itself is exceptional, even when compared to the highest performance CCDs. Not even slow-scan CCDs are capable of this level of read noise performance. High-resolution, slow-scan CCDs are typically characterized by seconds per frame rather than frames per second. The fact that the sCMOS device can achieve 1 electron rms read noise while reading out 5.5 megapixels at 30 fps renders it truly extraordinary in the market. Furthermore, the sensor is capable of achieving 100 full fps with a read noise 1.3 electrons rms. By way of comparison, the lowest noise Interline CCD reading out only 1.4 megapixels at ~ 16 fps would do so with ~ 10 electrons read noise.

Greater speed is available through selection of ‘region of interest’ sub-windows, such that the field of view can be traded off to achieve extreme temporal resolution. Table 1 shows frame rates that can be expected from a series of sub-window sizes, in both rolling shutter and global shutter modes of operation (the distinction between these two modes is explained later in this paper). Note that each of the sub-windows can be expanded to full width in the horizontal direction and

still maintain the same indicated frame rate. For example, both 1390 x 1024 and 2560 x 1024 sub-window sizes each offer 220 fps in rolling shutter mode. This is important information for some applications that can take advantage of an elongated (letter box shape) region of interest.

The low noise readout is complemented by a high dynamic range of 30,000:1. Usually, for CCDs or EMCCDs to reach their highest dynamic range values, there needs to be a significant compromise in readout speed, yet sCMOS can achieve this value while delivering 30 fps. Furthermore, the architecture of sCMOS allows for high dynamic range by offering a large well depth, despite the small pixel size. By way of comparison, a 1.4 megapixel Interline with similarly small pixels achieves only ~1,800:1 dynamic range at 16 fps.

Part 3 - Comparing sCMOS to other leading scientific imaging technologies

A short comparative overview of sCMOS is provided in Table 2. For the purposes of this exercise, we limited the comparison to Interline CCD and EMCCD technologies, given their popularity across the range of scientific imaging applications. Interline CCDs are typified by a choice of 1.4 megapixel or 4 megapixel sensors. The most popular EMCCD sensors are 0.25 or 1 megapixel, typically offering up to 30 fps.

It is apparent that across most parameters, sCMOS presents a distinct performance advantage, notably in terms of noise, speed, dynamic range and field of view/resolution. Importantly, these advantages are met largely without compromise. Whilst the read noise of sCMOS is very low, EMCCD technology still maintains the distinct advantage of being able to multiply the input signal above the read noise floor, thus rendering it negligible (<1 e⁻). The majority of EMCCD cameras purchased at this time are also of back-illuminated, having ~ 90% QE max, which also feeds into the sensitivity comparison. For this reason, EMCCD technology will still hold firm in extreme low-light applications that require this level of raw sensitivity, and are willing to sacrifice on the enhanced resolution, field of view, dynamic range and frame rate that sCMOS can offer.

Parameter	Neo sCMOS	Interline CCD	EMCCD
Sensor Format	5.5 megapixel	1.4 to 4 megapixel	0.25 to 1 megapixel
Pixel Size	6.5 μm	6.45 to 7.4 μm	8 to 16 μm
Read Noise	1 e ⁻ @ 30 fps 1.3 e ⁻ @ 100 fps	4 -10 e ⁻	< 1e ⁻ (with EM gain)
Full Frame Rate (max.)	Sustained: >30 fps full frame Burst: 100 fps full frame	3 to 16 fps	~ 30 fps
Quantum Efficiency (QE)	57%	60%	90% ‘back-illuminated’ 65% ‘virtual phase’
Dynamic Range	30,000:1 (@ 30 fps)	~ 3,000:1 (@ 11 fps)	8,500:1 (@ 30 fps with low EM gain)
Multiplicative Noise	none	none	1.41x with EM gain (effectively halves the QE)

Table 2 - Comparison summary of typically specifications of Interline CCD and EMCCD technologies compared to sCMOS technology.

Figures 1 to 4 show the results of head to head sensitivity comparisons, pitching a prototype 5.5 megapixel sCMOS camera against a 1.4 megapixel Interline CCD device, and also against 1 megapixel back-illuminated EMCCD. The sCMOS was set up to image at 560 MHz, this readout speed capable of achieving 100 full fps, with only 1.3 electrons read noise. The Interline CCD camera, an Andor 'Clara', was read out at 20 MHz, achieving 11 fps with 5 electrons read noise (representing extreme optimization of this sensor at this speed). The EMCCD camera, an Andor iXon 888, was read out at 10 MHz with x300 EM gain amplification, achieving 9 fps with 0.15 electrons effective read noise. Low light imaging conditions were created using (a) a light tight imaging rig, fitted with a diffuse, intensity-variable 622 nm LED light source and mask overlay (consisting either an array of holes or a USAF resolution chart); (b) both confocal spinning disk and conventional widefield fluorescence microscopes, imaging fixed bovine epithelial cells labelled with BODIPY FL (emission max. ~ 510nm).

The LED rig proved excellent for comparing sensitivity under extreme low light conditions, using two low light intensity settings; 10 photons/6.5 μm and 32 photons/6.5 μm . The SNR superiority of sCMOS over even well-optimized Interline CCD technology can clearly be observed, manifest as better contrast of signal against a less noisy read noise background, resulting also in better resolution of features. However, comparison of the two technologies against back-illuminated EMCCD (figure 2) at the weakest LED setting, showed that the < 1 electron noise floor and higher QE of the EMCCD resulted in notably superior contrast of the weak signal from the noise floor.

Figures 3 and 4 show clear differences in low light signal contrast between sCMOS and Interline cameras, employed on both spinning disk and widefield fluorescence microscopy set-ups. Again the contrast difference arises from the read noise difference between the two technologies.

To further supplement the relative sensitivity performance of these imaging technologies, theoretical SNR plots that are representative of these three technologies are given in Figures 5 and 6. For this comparative exercise, specifications were used that reflect the most sensitive Interline CCD and back-illuminated EMCCD sensors on the market today.

Figure 5 shows how the SNR of sCMOS compares to that of Interline CCD across a range of photon fluxes (i.e. incident light intensities). The pixel size differences between the two sensor types is negligible, thus there is no need to further correct for differing areas of light collection per pixel. The sensitivity differences between the two technology types is reflected in the marked variance between the respective SNR curves at low to moderate photon fluxes. At higher photon fluxes, there is no 'cross-over' point between sCMOS and Interline CCD curves. Similar QE and pixel size ensures that the Interline CCD will never surpass the SNR performance of sCMOS. In fact, due to the significantly lower read noise, the sCMOS exhibits markedly better signal-to-noise than the Interline CCD until several hundred photons/pixel at which point the two curves merge as the read noise of both sensors becomes negligible compared to the shot noise.

Figure 6 shows SNR plots that compare sCMOS and Interline CCD sensors with that of back-illuminated EMCCD sensors. The plot assumes that all three sensors have the same pixel size, which could effectively be the case if the ~ 6.5 μm pixels of both the sCMOS and Interline CCD sensors were to be operated with 2 x 2 pixel binning,

to equal a 13 μm EMCCD pixel (representative of a popular back-illuminated EMCCD sensor on the market). As such, the photon flux is presented in terms of photons per 13 μm pixel (or 2 x 2 binned super-pixel), relating to an actual pixel area of 169 μm^2 . There are two notable cross-over points of interest, relating to where the EMCCD S/N curve crosses both the sCMOS and Interline CCD curves, which occur at photon flux values of ~ 55 photons/pixel and ~ 225 photons/pixel, respectively. At photon fluxes lower than these cross-over points the EMCCD delivers better S/N ratio, and worse S/N ratio at higher photon fluxes. The reason that a back-illuminated EMCCD with negligible read noise does not exhibit higher S/N right throughout the photon flux scale, is due to the multiplicative noise of the EMCCD plot (which effectively increases the shot noise).

Figures 7 and 8 show widefield fluorescence microscope images, taken using x60 and x100 magnifications respectively, comparing 5.5 megapixel sCMOS to 1.4 megapixel Interline CCD technology. Each clearly reveal the markedly larger field of view capability of the 5.5 megapixel sCMOS sensor. Since each sensor type has ~ 6.5 μm pixel pitch, allowing for adequate Nyquist oversampling at the diffraction limit, it is unsurprising that each show virtually identical resolution of fine intracellular structure under brighter conditions, as shown in Figure 8. At low photon fluxes however, typified in figures 3 and 4, the higher read noise of the Interline device results in greater sacrifice in resolution and contrast. This is a decisive point for live cell measurements, which often necessitate the use of low illumination energies.

Conclusion

After several decades of technology maturation, we have now reached a 'leap forward' point, where we can confidently claim that the next significant wave of advancement in high-performance scientific imaging capability has come from the CMOS imaging sensor technology stable. Scientific CMOS (sCMOS) technology stands to gain widespread recognition across a broad gamut of demanding imaging applications, due to its distinctive ability to simultaneously deliver extremely low noise, fast frame rates, wide dynamic range, high quantum efficiency, high resolution and a large field of view. Comparisons with other current 'gold standard' scientific image detector technologies show that the CIS 2051 sCMOS sensor, optimized in the Andor Neo camera, out-performs even high-performing interline CCD camera in most key specifications whilst maintaining a Snapshot exposure mode for broader application flexibility.

For extremely low light applications that require absolute raw sensitivity at respectably fast frame rates, a high performance back-illuminated EMCCD camera (present in the Andor iXon range) maintains an application advantage.

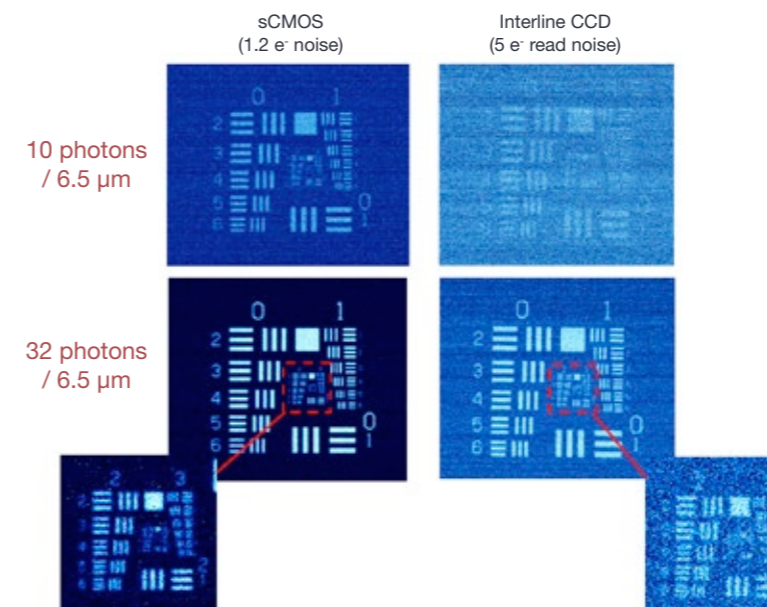

Figure 1 - Comparative low light images of a USAF resolution chart, showing Andor sCMOS (1.3 electrons read noise @ 560 MHz) vs Interline CCD (5 electrons read noise @ 20 MHz), under the two lowest LED settings.

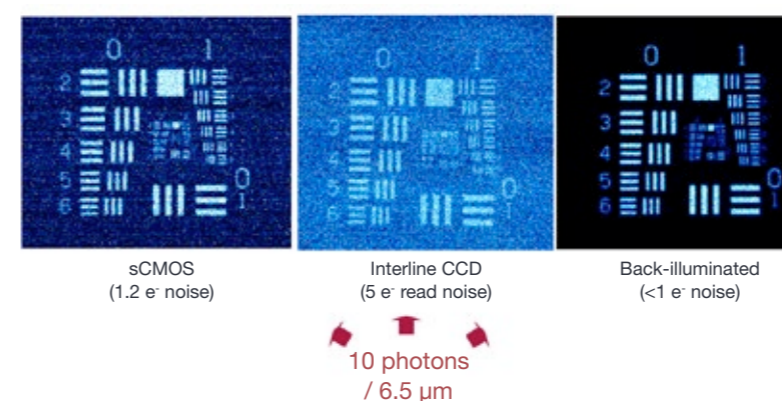

Figure 2 - Comparative low light images taken with Andor sCMOS (1.3 electrons read noise @ 560 MHz) vs Interline CCD (5 electrons read noise @ 20 MHz) vs back-illuminated EMCCD (< 1 e⁻ read noise), under extremely low light conditions (10 photons / 6.5 μm setting). sCMOS and Interline CCD were 2 x 2 binned in order to have the same effective pixel pitch (and light collection area per pixel) as the 13 μm pixel of the EMCCD sensor.

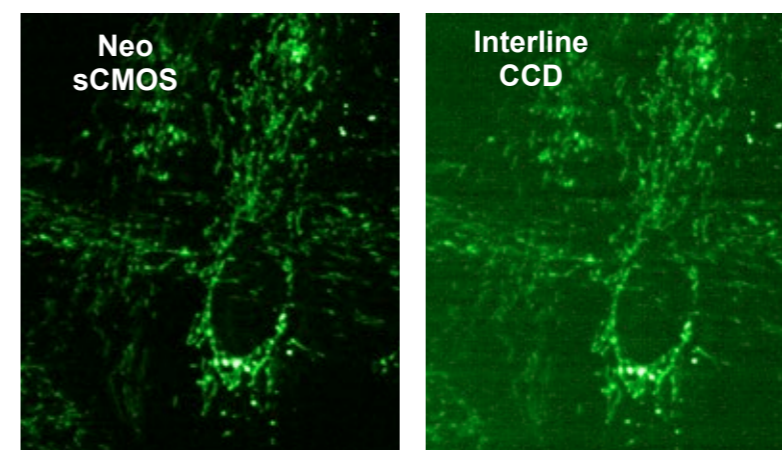

Figure 3 - Comparative low light images taken with Andor sCMOS (1.3 electrons read noise @ 560 MHz) vs Interline CCD (5 electrons read noise @ 20 MHz) of fluorescently labelled fixed cell using a CSU-X spinning disk confocal microscope (x60 oil objective), each 100 ms exposure, same laser power, displayed with same relative intensity scaling. Note, the field of view is limited by the aperture size of the CSU-X, which is matched to the 1.4 megapixel Interline sensor.

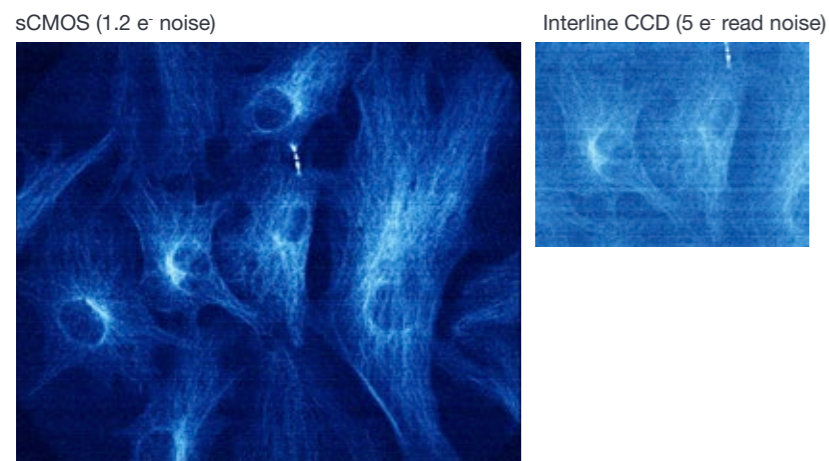

Figure 4 - Comparative low light fluorescence microscopy images taken with Andor sCMOS (1.3 e⁻ @ 560 MHz) vs Interline CCD (5 e⁻ @ 20 MHz) under low light conditions, typical of those employed in dynamic live cell imaging. ND filters on a widefield fluorescence microscope were used to reduce light levels relative to the read noise floor.

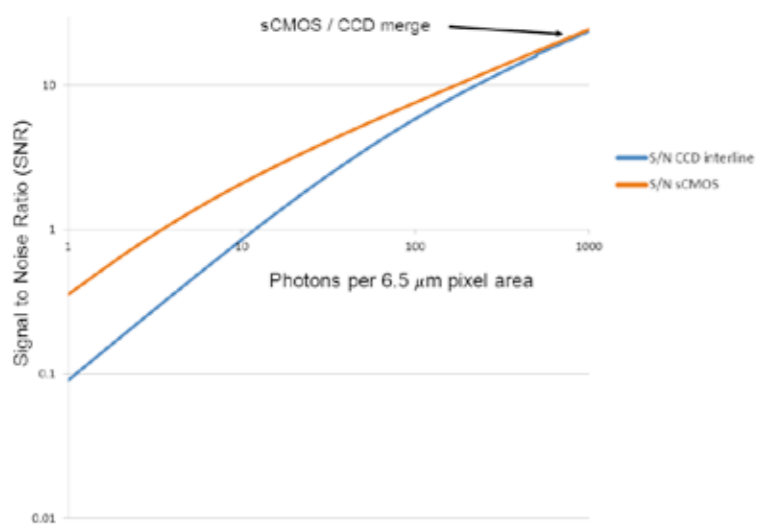

Figure 5 - Theoretical Signal to Noise plot comparisons for sCMOS vs Interline CCD sensors. Photon flux (i.e. input light intensity) is given in terms of photons per 6.5 μm pixel of each sensor type.

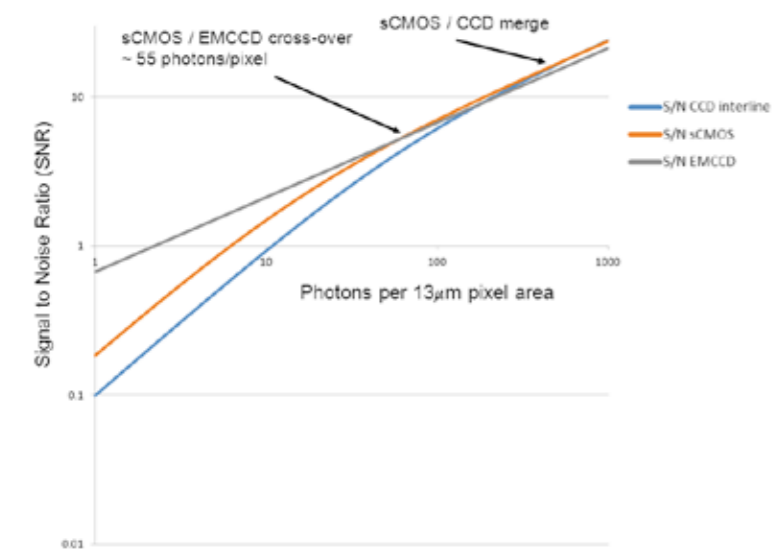

Figure 6 - Theoretical Signal to Noise plot comparisons for sCMOS vs Interline CCD vs back-illuminated EMCCD sensors. For purposes of a objective comparison, it is assumed that the ~6.5 μm pixels of the sCMOS and Interline CCD sensors are 2 x 2 binned in order to equal a 13 μm pixel of a back-illuminated EMCCD.

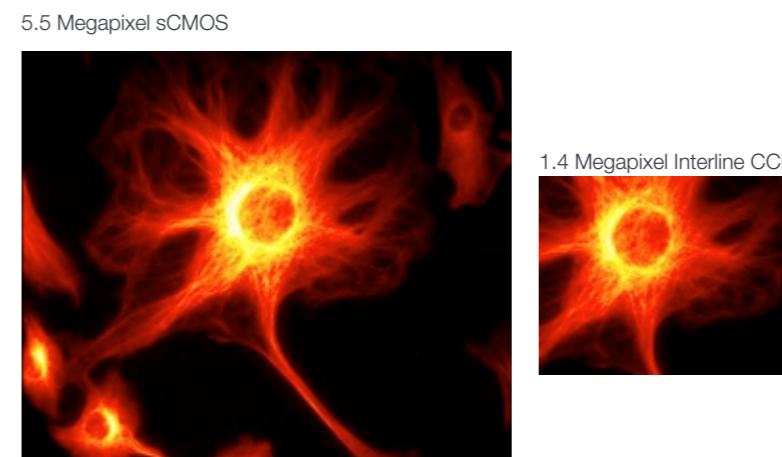

Figure 7 - Field of view comparison of two technologies; x60 magnification; 1.25 NA; 5.5 megapixel Andor sCMOS vs 1.4 megapixel Interline CCD (each have ~ 6.5 μm pixel pitch). sCMOS is capable of offering this larger field of view @ 100 frame/s with 1.3 e⁻ read noise.

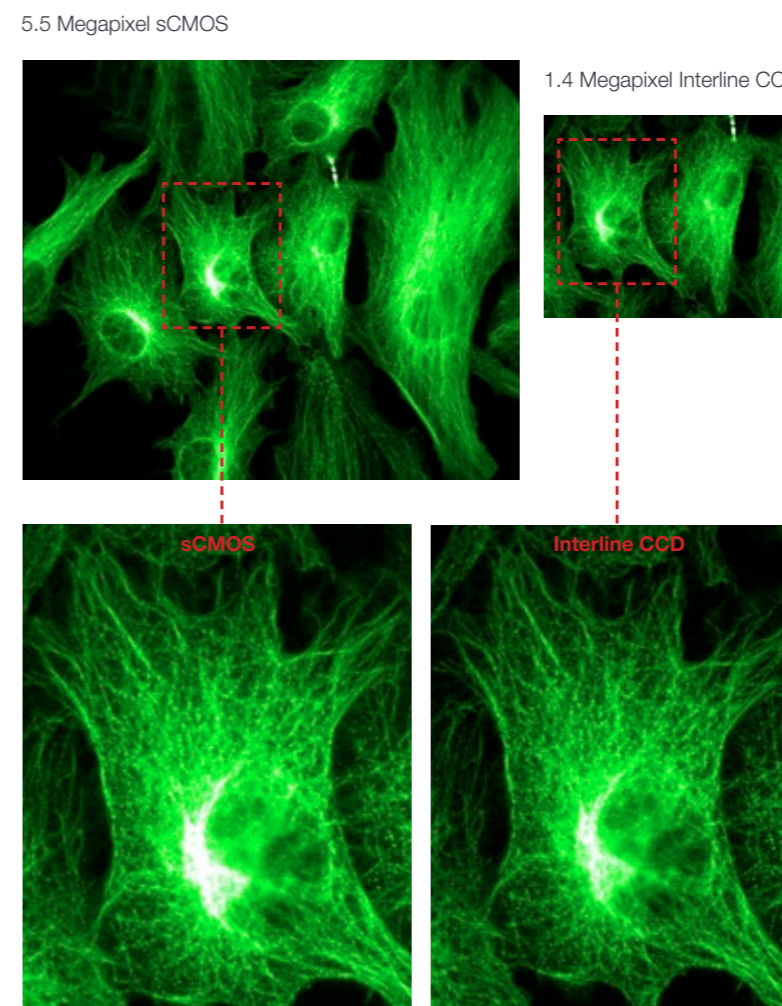

Figure 8 - Field of view and resolution comparison of two technologies; x100 magnification; 1.45 NA; 5.5 megapixel Andor sCMOS vs 1.4 megapixel Interline CCD (each have ~ 6.5 μm pixel pitch).

Technical Note

Andor sCMOS PC Recommendations and Data Flow Considerations

Andor's sCMOS camera solutions are capable of data rates that are markedly faster than other scientific camera technologies on the market. The pixel readout speed that yields the fastest frame rate of 100 fps (full frame) relates to a data rate of ~ 840 MB/sec (single amplifier mode); ~ 1120 MB/sec (dual amplifier mode).

(a) Data spooling – awareness of the ‘bottlenecks’

Some applications require fast kinetic series acquisitions that are sustainable for a long duration. In such cases, the data must be spooled continuously to either a suitable fast PC hard drive solution or PC RAM, each with sufficient storage capacity.

The data transfer rates achievable over more extended kinetic series are limited either by the data bandwidth of the Camera Link interface between camera and PC or by the hard drive write speed (if spooling to hard drive is selected). The maximum sustained speeds are ultimately limited by the interface bandwidth in addition to time taken for a ‘read request’ to be sent by the software to retrieve the next image block. The single Camera Link interface (‘3-tap’) has a bandwidth limitation of ~ 250MB/sec, which translates to ~ 30 frames/sec of 5.5 MP image size, single amplifier dynamic range mode. The dual Camera Link interface (‘10-tap’) has a bandwidth limitation of 850 MB/sec, translating to the full 100 fps in single amplifier mode. Thus, to achieve maximum available sustained speeds, a PC configuration should be capable of writing/spooling data at faster than this rate (see section D).

The maximum length of a kinetic series is determined by the capacity of PC RAM or hard drive that is assigned for spooling. The issue of determining achievable speeds is further compounded by the fact that data rates are also adjusted by user selected variables such as exposure time, pixel readout speed, ROI size, hardware binning or single/dual amplifier dynamic range modes.

(b) Dataflow Monitor

In order to better estimate any limitations of system bottlenecks on a requested kinetic series, Andor have developed the Dataflow monitor for Neo and Zyla, accessible through the set-up dialogue of the Solis acquisition software. This will provide ‘up-front’ estimation as to whether the kinetic series conditions that have been requested by the user are likely to be compatible or incompatible with the data transfer and write bandwidths available from Camera Link interface and PC hard drive respectively.

The Dataflow monitor will also estimate the available storage capacity of camera, PC RAM or hard drive to determine whether the length of requested kinetic series is within storage limits. This should better inform the user of potential data speed or capacity complications in advance of beginning an acquisition. The figure 1 below illustrates a scenario in which the Dataflow monitor has accepted and flagged a kinetic series request, respectively.

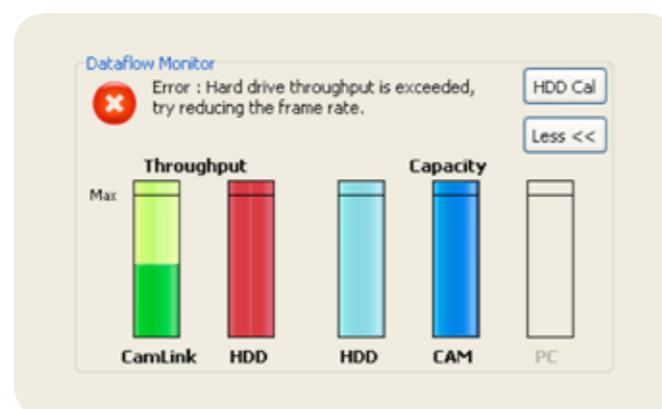

Figure 1 – The Dataflow monitor has raised a warning against the requested kinetic series. In this case the data rate exceeds that of the hard drive write speed. Options to rectify include: (a) reduce frame rate / lengthen exposure time (b) reduce ROI size (c) use hardware binning (d) use single amplifier mode (e) reduce kinetic series length to be within the 4 GB on-head camera memory (e) spool to PC RAM (if greater than 4 GB).

(c) Using Neo on-head memory buffer

Neo sCMOS is uniquely equipped with 4GB of on-head memory buffer, through which data is flowed. This buffer can be used to burst data to until full, even at maximum frame rate of the camera. Frames will enter and leave this memory buffer continuously, but the speed of transfer to PC will be dictated by either Camera Link interface bandwidth or hard drive write speed (if hard disk spooling is selected), alongside any other associated ‘handshaking’ or ‘processing’ overheads associated with the acquisition software. The severity of the data transfer bottleneck (i.e. the rate that data can leave the camera memory) therefore dictates exactly how many frames in a kinetic series can be recorded to camera memory buffer before it becomes full.

In reality, one might expect capacity for between 450 to 500 frames when operating at 100 frames/sec, 5.5 megapixel (full resolution) in single amplifier mode (11-bit). In other words, the buffer can hold 4 to 5 seconds worth of kinetic series data under maximum frame rate conditions of the camera. If a smaller ROI size is selected, one has the option to either (a) maintain frame rate and extend kinetic series length beyond 5 seconds, or (b) achieve faster frame rates but stay within the 4 to 5 sec threshold.

The Neo memory buffer can be successfully utilised to achieve respectably fast acquisition rates from modestly specified PC

configurations. For example, a hard drive may only be capable of writing data at 25 fps, yet a speed of 40 fps is required for a particular experiment. In this instance, it is still possible to acquire at 40 fps, the memory buffer filling at a rate of 15 fps. Under these circumstances, the kinetic acquisition could be allowed to progress for ~ 30 secs before the buffer becomes filled.

(d) PC Recommendations - Speed tests

Part 1 – Zyla ‘10-tap’ kinetic series tests

Table 1 outlines some PC solutions for Zyla sCMOS that were in-house tested by Andor over extensive kinetic series lengths. The dual Camera Link ‘10-tap’ configuration of the camera was employed, representing the option that is chosen for fastest possible frame rate performance.

The test utilised Solis acquisition software, internally triggered, rolling shutter mode and 560 MHz pixel readout speed, in both 11 bit (single amplifier) and 16-bit (dual amplifier) data range configurations. The results indicate for each system configuration the sustainable frame rates, limited only by the capacity of hard drive or RAM, depending on spooling option selected.

- Each PC configuration is based on a Dell T5500 ‘base’ system.
- The speed tests represented in table 1 were tested using extensive kinetic series lengths of several thousand frames:

- 2560 x 2160 – 6,000 frames (except System B with 16-bit range)
- 2064 x 2048 – 6,000 frames (except System B with 16-bit range)
- 1980 x 1080 – 8,000 frames
- 1396 x 1024 – 8,000 frames
- 512 x 512 – 10,000 frames
- 128 x 128 – 15,000 frames

• System A utilizes 4 x 250 GB SSD hard drives configured in RAID 0 for data spooling, an additional fifth slower hard drive assigned to the operating system (Windows 7 64-bit). The complete PC configuration is as follows:

- Dell Precision T5500
- Intel Xeon E5620 2.4 GHz Quad Core
- 4GB RAM
- Windows 7 64Bit Professional
- Crucial M4 SSD x 4 with Firmware upgrade to 000F, configured for RAID0
- LSI MegaRAID SAS 9260-8i RAID Controller
- Dell 500 GB HDD 7200 rpm for Operating System

• System B utilizes 56GB of PC RAM for direct spooling. Solis acquisition software is a 32-bit application and thus a RAMDISK application was utilised to ‘effectively’ convert RAM into a fast spool hard drive that is not limited to 4 GB blocks. 48 GB were allocated for this purpose. Note, the RAMDISK would not be required with a 64-bit acquisition engine, such as the Andor SDK.

	System A (RAID HD)	System B (RAM)
Platform	Dell T5500	Dell T5500
Processor	Intel Xeon E5620 2.4GHz Quad Core	Intel (R) Xeon (R) CPU E5640 @ 2.67 GHz Dual Core
Memory	4 GB	56 GB RAM Disk
Hard drives	4 x 250 GB SSD hard drives configured in RAID 0 for spooling Dell 500 GB HDD 7200 rpm for Operating System	Dell 500 GB HDD 7200 rpm for Operating System (Not utilized for spooling)

Array size / ROI	Data Range	Frame Rate	Series length	Frame Rate	Series length
2560 x 2160	11-bit	100.1 fps	6,000	100.2 fps	6,000
	16-bit	75.7 fps	6,000	76.3 fps	4,535*
2048 x 2048	11-bit	105.4 fps	6,000	105.4 fps	6,000
	16-bit	99 fps	6,000	100.1 fps	5,932*
1920 x 1080	11-bit	202.5 fps	8,000	198.2 fps	8,000
	16-bit	200 fps	8,000	198.2 fps	8,000
1392 x 1040	11-bit	208.3 fps	8,000	207.3 fps	8,000
	16-bit	207.3 fps	8,000	207.3 fps	8,000
512 x 512	11-bit	420.2 fps	10,000	419.5 fps	10,000
	16-bit	420.2 fps	10,000	419.5 fps	10,000
128 x 128	11-bit	1630.4 fps	15,000	1,639.9 fps	15,000
	16-bit	1630.4 fps	15,000	1,639.9 fps	15,000

* Series length limited by storage capacity of RAMDISK (48 GB allocated)

Table 1 - Frame rates achieved by Zyla ‘10-tap’ for 2 different PC configurations, tested over kinetic series lengths of between 6,000 and 15,000 frames

In consideration of the above tests, the speeds attained from System B (RAM) can be considered to approximate the maximum sustained frame rate possible for each ROI size. It is clear that results for System A were limited more by the write capacity of the hard drive configuration.

From an SDK integration and driver development standpoint, it is important to note that the maximum sustained frame rates relate to how fast data can be retrieved from the camera. However, additional processing overheads, including saving data to the hard drive, could impact these figures.

Part 2 – Neo ‘3-tap’ kinetic series tests

Table 2 outlines some PC solutions for Neo sCMOS that were in-house tested by Andor over extensive kinetic series lengths. The test utilised Solis acquisition software, internally triggered, rolling shutter mode and 560MHz pixel readout speed, in both 11 bit (single amplifier) and 16-bit (dual amplifier) data range configurations. The results indicate for each system configuration the frame rates achieved over very long kinetic series lengths, spooling to either hard drive (systems A and B) or PC RAM (system C).

Each PC configuration is based on the same ‘base’ system, which is a Dell T550 with 2.6GHz Quad Core, including 3 x 10,000 rpm 600GB SATA hard drives. One of the three available hard drives is assigned to the operating system (Windows 7 64-bit), the remaining two drives configured in RAID 0 for fast data spooling.

- The speed tests represented in table 1 were tested using extensive kinetic series lengths of several thousand frames:
 - 2560 x 2160 – 6,000 frames (except System C)
 - 2064 x 2048 – 6,000 frames (except System C with 16-bit range)
 - 1396 x 1024 – 8,000 frames
 - 528 x 512 – 10,000 frames
 - 144 x 128 – 15,000 frames

- System A makes use of the RAID 0 dual hard drives for direct spooling.

- System B utilizes 3x 15K 600GB SAS hard drives configured in RAID 0 for data spooling (an additional fourth hard drive assigned to the operating system).

- System C utilizes 48GB of PC RAM for direct spooling. Solis acquisition software is a 32-bit application and thus a RAMDISK application was utilised to ‘effectively’ convert RAM into a fast spool hard drive that is not limited to 4GB blocks. 44GB were allocated for this purpose. Again note that the RAMDISK would not be required with a 64-bit acquisition engine, such as the Andor SDK. Note also that again the 3x SATA drives are maintained as storage drives.

Appendix

- In order to drive fastest data spooling rates, especially from 10-tap Zyla sCMOS, it is highly recommended that acquisition PCs are dedicated for this purpose and that other functions or applications are not being performed in the background, particularly during data acquisition. Tests represented in this technical note were under such stringent conditions.
- Both SDK 3 and Solis are compatible with a 64-bit OS. A 64-bit OS is recommended for most efficient spooling, where possible. Note however that iQ software requires a 32-bit OS
- 64-bit 3rd party software packages must use the 64-bit SDK3 and operate on 64-bit OS
- 64-bit software can spool directly to PC RAM that is greater than 4 GB
- RAMDISK is the ONLY way to make use of > 4 GB PC RAM in a 32-bit application
- Andor’s only tested RAMDISK solution can be accessed through this link: SuperSpeed LLC RamDisk Plus 10.x (32 bit) superspeed.com

		System A Intermediate Speed (RAID HD)		System B Maximum Speed (RAID HD)		System C Maximum Speed (RAM)	
		Dell T5500		Dell T5500		Dell T5500	
Platform		Dell T5500		Dell T5500		Dell T5500	
Processor		2.6 GHz Quad Core		2.6 GHz Quad Core		2.6 GHz Quad Core	
Memory		4 GB		4 GB		48 GB	
Hard drives		3 x 10K 600 GB SATA		4 x 15K 600 GB SAS		3 x 10K 600 GB SATA	
Array size / ROI	Data Range	Frame Rate	Series length	Frame Rate	Series length	Frame Rate	Series length
2560 x 2160 (full resolution)	11-bit	23 fps	6,000	32.5 fps	6,000	32.5 fps	5,200*
	16-bit	18 fps	6,000	24.5 fps	6,000	24.5 fps	4,000*
2048 x 2048	11-bit	30 fps	6,000	40.5 fps	6,000	40.5 fps	6,000
	16-bit	22.5 fps	6,000	32 fps	6,000	32 fps	5,200*
1396 x 1024	11-bit	62 fps	8,000	83 fps	8,000	83 fps	8,000
	16-bit	47 fps	8,000	83 fps	8,000	83 fps	8,000
512 x 512	11-bit	125 fps	10,000	181 fps	10,000	181 fps	10,000
	16-bit	94 fps	10,000	181 fps	10,000	181 fps	10,000
128 x 128	11-bit	530 fps	15,000	1,098 fps	15,000	1,087 fps	15,000
	16-bit	395 fps	15,000	1,098 fps	15,000	1,087 fps	15,000

* Series length limited by storage capacity of RAMDISK (44 GB allocated)

Table 2 - Frame rates achieved by Neo (3-tap) for 3 different PC configurations, tested over kinetic series lengths of between 6,000 and 10,000 frames, significantly exceeding the 4GB on-head memory buffer of the Neo camera.

Technical Note

Understanding Read Noise in sCMOS

New sCMOS technology boasts an ultra-low read noise floor that significantly exceeds that which has been available from even the best CCDs, and at several orders of magnitude faster pixel readout speeds. For those more accustomed to dealing with CCDs, it is useful to gain an understanding of the nature of read noise distribution in CMOS imaging sensors.

Read Noise

CCD architecture is such that the charge from each pixel is transferred through a common readout structure, at least in single output port CCDs, where charge is converted to voltage and amplified prior to digitization in the Analogue to Digital Converter (ADC) of the camera. This results in each pixel being subject to the same readout noise. However, CMOS technology differs in that each individual pixel possesses its own readout structure for converting charge to voltage. In the CIS 2051 sCMOS sensor, each column possesses dual amplifiers and ADCs at both top and bottom (facilitating the split sensor readout). During readout, voltage information from each pixel is directly communicated to the appropriate amplifier/ADC, a row of pixels at a time; see tech note on Rolling and Global Shutter modes.

As a consequence of each pixel having its own individual readout structure, the overall readout noise in CMOS sensors is described as a distribution, as exemplified in figure 1, which is a representative noise histogram from a Neo sCMOS camera at the fastest readout speed of 560 MHz (or 280 MHz x 2). It is standard to describe noise in CMOS technology by citing the median value of the distribution. In the data presented, the median value is 1.1 electron rms. This means that 50% of pixels have a noise less than 1.1 electrons, and 50% have noise greater than 1.1 electrons. While there will be a small percentage of pixels with noise greater than 2 or 3 electrons, observable as the low level tail towards the higher noise side of the histogram, it must be remembered that a CCD Interline camera reading out at 20 MHz would have 100% of its pixels reading out with read noise typically ranging between 6 and 10 electrons rms (depending on camera manufacture).

Insight into the sCMOS architecture

The sensor features a split readout scheme in which the top and bottom halves of the sensor are read out independently. Each column within each half of the sensor is equipped with dual column level amplifiers and dual analog-to-digital converters (ADC); see technical note of Dual Column Amplifiers for more detail. This ‘split’ sensor format was designed to help minimize read noise while maintaining extremely fast frame rates. Each pinned-photodiode pixel has 5 transistors (‘5T’ design), enabling the novel ‘global shutter’ mode and also facilitating correlated double sampling (CDS), to further reduce noise, and a lateral anti-blooming drain. The sensor is integrated with a microlens array that serves to focus much of the incident light per pixel away from the transistors and onto the exposed silicon, enhancing the QE (analogous to use of microlenses in Interline CCDs to focus light away from the column masks).

The sensor is configured to offer low dark current and extremely low read noise with true CDS. Non-linearity is less than 1% and is further correctable to < 0.2%. The sensor also has anti-blooming of >10,000:1, meaning that the pixels can be significantly oversaturated

without charge spilling into neighboring pixels. It is also possible to use the anti-blooming capability to hold all or parts of the sensor in a state of ‘reset’, even while light is falling on these pixels.

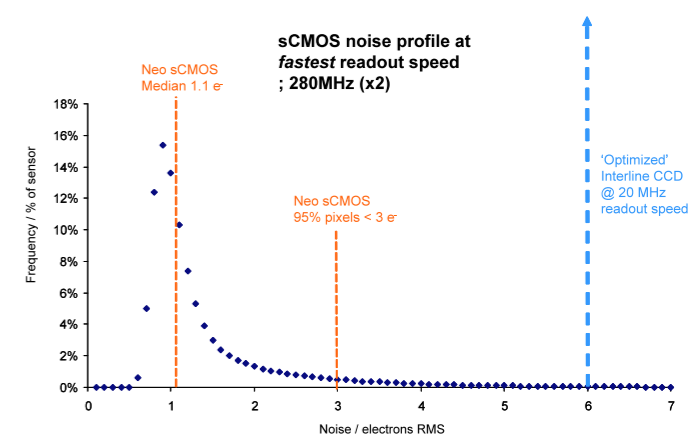

Figure 1 - Representative histogram showing read noise distribution at fastest readout speed of 560 MHz. The median value of 1.1 e⁻ means 50% pixels have less than 1 e⁻ and 50% have greater than 1 e⁻. The line at 6 e⁻ represents a typical read noise value from a well optimized Interline CCD – all pixels in a CCD share the same noise value.

Spurious Noise Filter

Andor’s Neo sCMOS camera comes equipped with an optional in-built FPGA filter to reduce the frequency of occurrence of high noise pixels. This real time filter corrects for pixels that are above 5 electrons rms and would otherwise appear as spurious ‘salt and pepper’ noise spikes in the image. The appearance of such noisy pixels is analogous to the situation of Clock Induced Charge (CIC) noise spikes in EMCCD cameras, in that it is due to the fact that we have significantly reduced the noise in the bulk of the sensor, such that the remaining small percentage of spuriously high noise pixels can become an aesthetic issue. The filter employed dynamically identifies such high noise pixels and replaces them with the mean value of the neighbouring pixels.

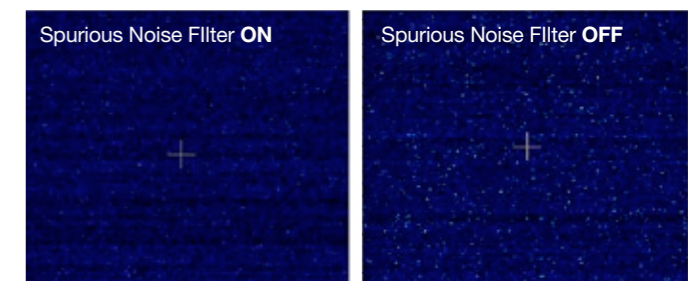
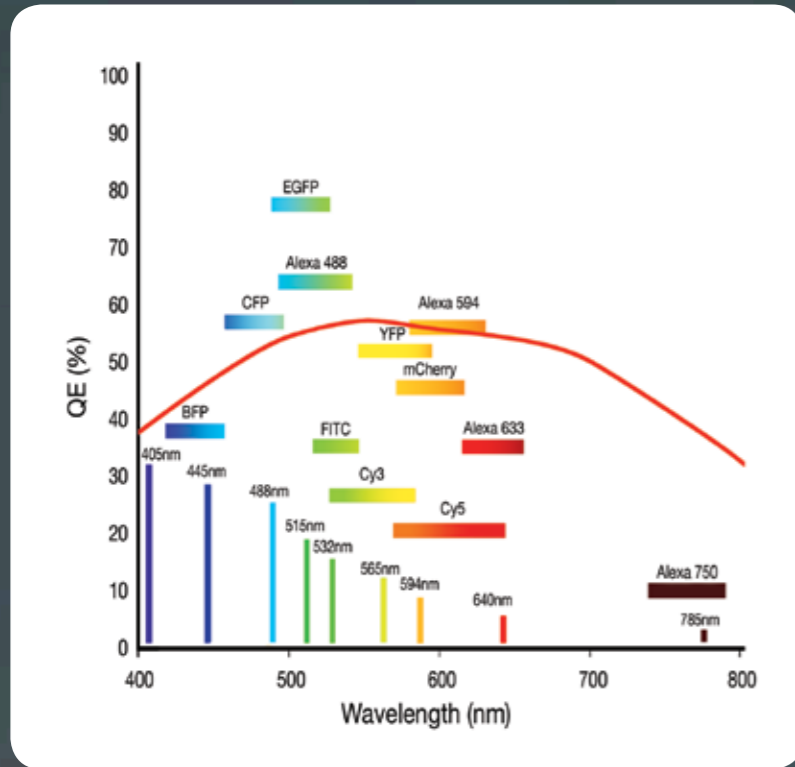

Figure 2 - Demonstration of Spurious Noise Filter on a dark image, 20 ms exposure time, 200 MHz (x2) readout speed (~ 1.2 e⁻ readnoise)



Neo sCMOS Quantum Efficiency (QE) curve, incorporating laser excitation lines and emission ranges of common fluorophore labels.

“

Without pushing it to the limit we managed to take 131 planes of the drosophila embryo in just 4 seconds (5.5 megapixels mode), which is practically instantaneous compared to the morphogenetic processes and out-perform by far everything we have tried before. The camera is made for SPIM microscopy!

”



Dr. Lars Hufnagel,
Developmental Biology Unit,
EMBL Heidelberg.

“

Our tests with Andor's new sCMOS camera have been highly encouraging. The combination of very low noise sensitivity at rapid frame rates, coupled with high pixel resolution, will enable us to reach previously unattainable throughput from our massively parallel, nanopore-based, single molecule sequencing approach.

”



Prof. Amit Meller
Associate Professor of Biomedical Engineering
and Physics,
Boston University



Main front cover image:

TIRF Microscopy of mouse cells showing the location of two distinct proteins which have been fluorescently labelled with green fluorescent protein (GFP) and red fluorescent protein (RFP). The green spots represent vesicles in the outer membrane of the cells and the red spots represent vesicles inside the cell.

Image courtesy of Dr. Roberto Zoncu, Whitehead Institute for Biomedical Research, MIT.

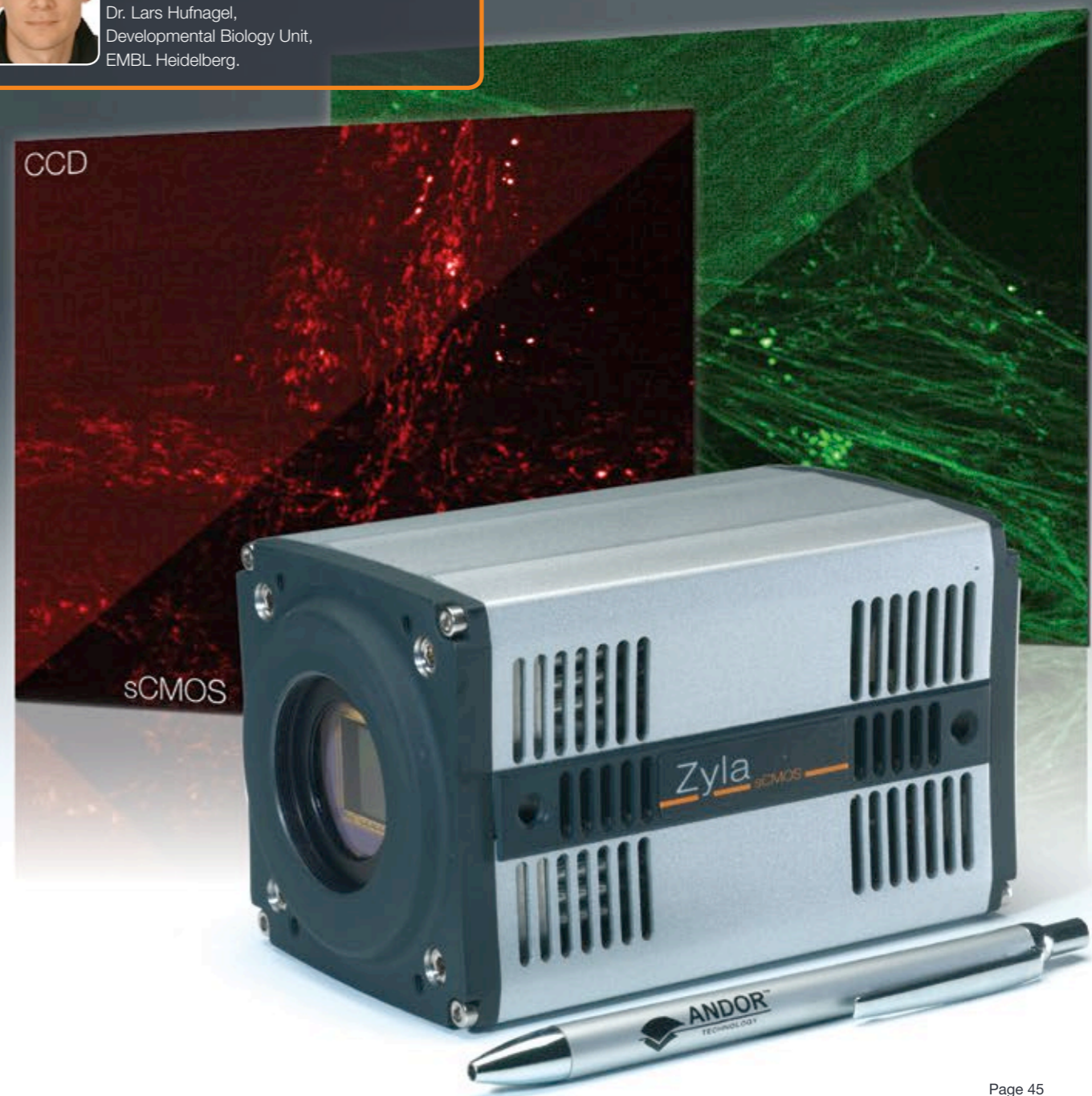

Andor Customer Support

Andor products are regularly used in critical applications and we can provide a variety of customer support services to maximise the return on your investment and ensure that your product continues to operate at its optimum performance.

Andor has customer support teams located across North America, Asia and Europe, allowing us to provide local technical assistance and advice. Requests for support can be made at any time by contacting our technical support team at andor.com/support.

Andor offers a variety of support under the following format:

- On-site product specialists can assist you with the installation and commissioning of your chosen product
- Training services can be provided on-site or remotely via the Internet
- A testing service to confirm the integrity and optimize the performance of existing equipment in the field is also available on request.

A range of extended warranty packages are available for Andor products giving you the flexibility to choose one appropriate for your needs. These warranties allow you to obtain additional levels of service and include both on-site and remote support options, and may be purchased on a multi-year basis allowing users to fix their support costs over the operating life cycle of the products.



Project part financed by the European Regional Development Fund under the European Sustainable Competitiveness Programme for Northern Ireland.

Head Office
7 Millennium Way
Springvale Business Park
Belfast BT12 7AL
Northern Ireland
Tel: +44 (28) 9023 7126
Fax: +44 (28) 9031 0792

North America
425 Sullivan Avenue
Suite 3
South Windsor, CT 06074
USA
Tel: +1 (860) 290 9211
Fax: +1 (860) 290 9566

Japan
4F NE Sarugakucho Building
2-7-6 Sarugaku-Cho
Chiyoda-Ku
Tokyo 101-0064
Japan
Tel: +81 (3) 3518 6488
Fax: +81 (3) 3518 6489

China
Room1213, Building B
Luo Ke Time Square
No. 103 Huizhongli
Chaoyang District
Beijing 100101
China
Tel: +86 (10) 5129 4977
Fax: +86 (10) 6445 5401

